

DETAIL OF BOLLARD WITH SLEEVE

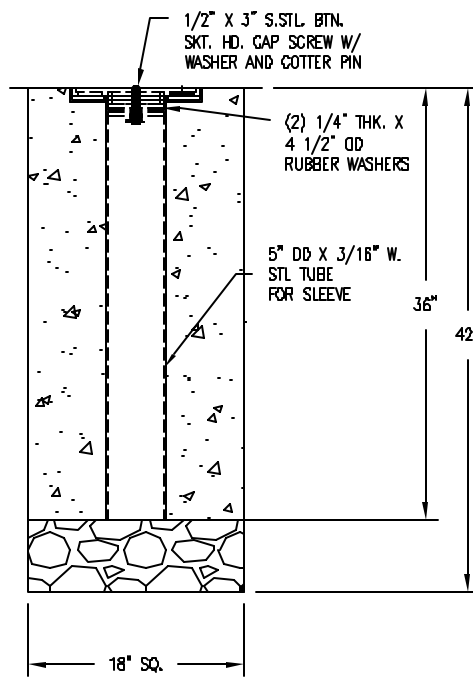

DETAIL OF CAP WITH SLEEVE

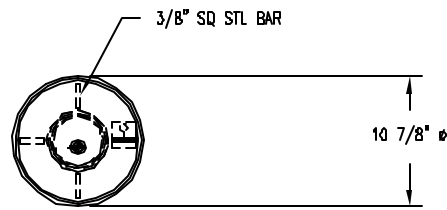
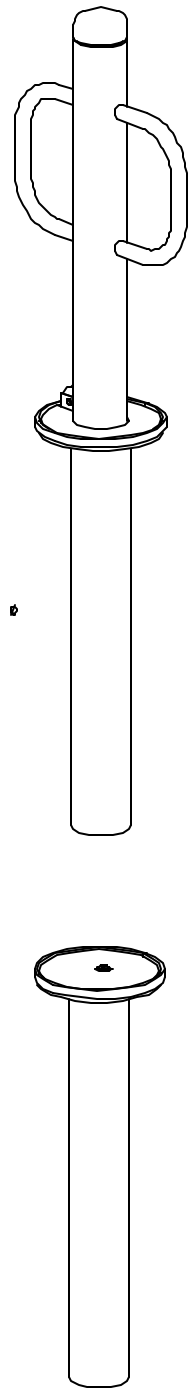

NOTES

- 1.) STL. MEMBERS COATED W/ ZINC RICH EPOXY THEN FINISHED W/ POLYESTER POWDER COATING.
- 2.) LOCKING DEVICE PROVIDED BY OTHER.



DuMor, inc.

P.O. Box 142 Mifflintown, PA 17059-0142

SCALE : NONE
 DATE DRAWN : 11/16/05
 DRAWN BY : HMD
 DATE REV. : 01/11/07
 REV. BY : ESS

TITLE :

BOLLARD

REV.
B

DRAWING NUMBER

401-36-2/S-1SL

SHEET
1 OF 2

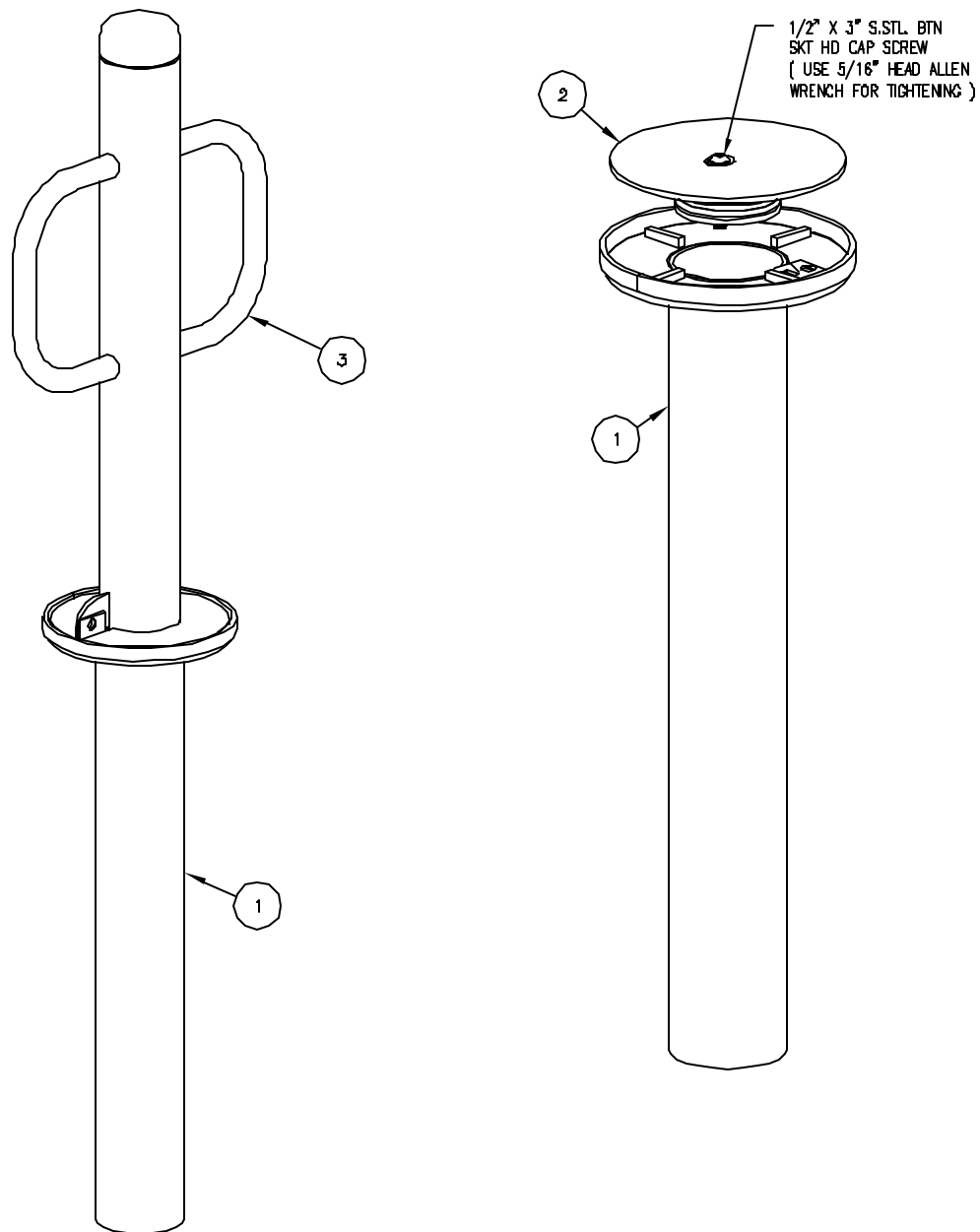

NOTES:

1. SET SLEEVE INTO FOOTER HOLDING PLUM, SQUARE AND HEIGHT SHOWN.
2. SLIDE BOLLARD INTO SLEEVE AFTER CONCRETE HAS HARDENED. BE SURE TO HAVE HINGE TAB SLIDE INTO BOLLARD BASE PLATE SLOT FOR LOCKING.
3. FOR USE OF CAP. WHEN BOLLARD IS REMOVED, PLACE CAP INTO SLEEVE. TIGHTEN CAP BY USING 1/2" X 3" BUTTON HEAD BOLT. THIS WILL COMPRESS THE RUBBER WASHERS THICKNESS AND EXPAND THE DIAMETER TO FIT SNUG TO SLEEVE.

ITEM	QTY	PART NO	DESCRIPTION
1	1	0-400-02	STL BOLLARD SLEEVE W/ HINGE
2	1	0-400-03	BOLLARD SLEEVE CAP ASSEMBLY
3	1	0-401-36-2/S1SL	36" STL BOLLARD, 2 LOOP, EMBED FOR SLEEVE

 DuMor, inc. P.O. Box 142 Mifflintown, PA 17059-0142	SCALE :	NONE	TITLE : BOLLARD	
	DATE DRAWN :	11/16/05		
	DRAWN BY :	HMD	REV.	DRAWING NUMBER 401-36-2/S-1SL
	DATE REV. :	01/11/07	B	
REV. BY :	ESS			