

PLACE GRILL ON SUPPORT, LINE UP HOLES IN INTERNAL PIN & POST. INSERT 3/8" ϕ ROLL PIN UNTIL GRILL ROTATES FREELY

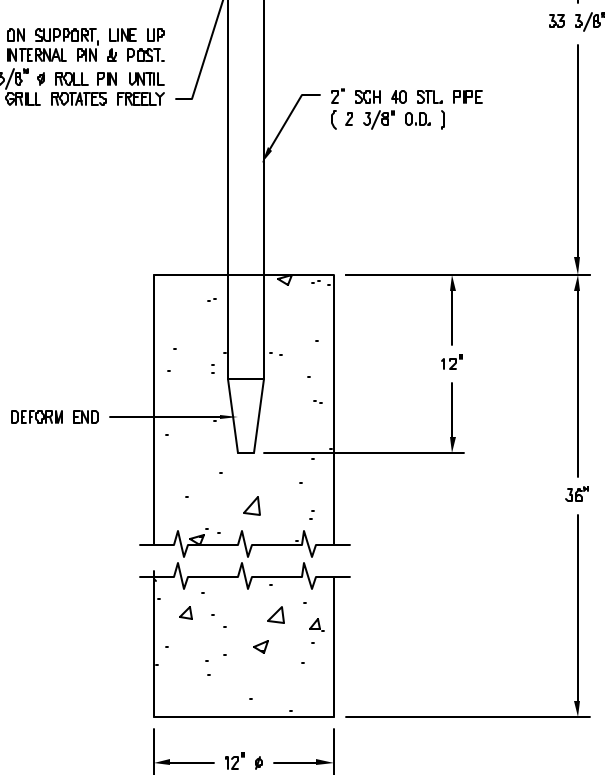

NOTES

- 1.) GRILL FINISHED W/ HEAT RESISTANT BLACK ENAMEL
- 2.) GRILL ROTATES FREELY 360° FOR DRAFT CONTROL



DuMor, inc.
P.O. Box 142 Mifflintown, PA 17059-0142

SCALE : NONE
DATE DRAWN : 3/22/94
DRAWN BY : GDC
DATE REV. : 9/28/05
REV. BY : JSB

TITLE :

GRILL

REV.
B

DRAWING
NUMBER

21-00

SHEET
1 OF 2

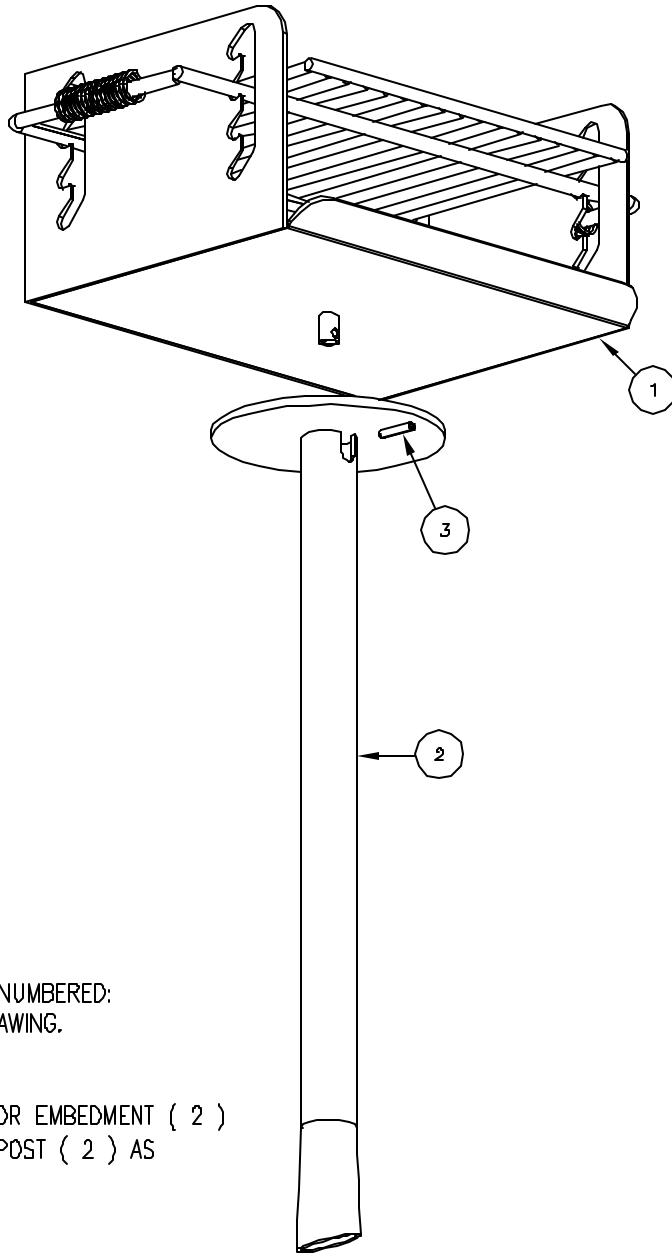

NOTE:

1. ACTUAL PARTS WILL NOT BE NUMBERED:
NUMBERS ONLY APPLY TO DRAWING.

STEP 1:

USE 1 - PC. SUPPORT POST FOR EMBEDMENT (2)
MOUNT AND LEVEL EMBEDMENT POST (2) AS
SPECIFIED ON SHEET 1

STEP 2:

USE 1 - PC. GRILL BODY ASSEMBLY (1)
1 - PC. 3/8" X 1 3/4" ROLL PIN (3)
AFTER CONCRETE HARDENS, PLACE GRILL BODY ASSEMBLY
(1) ON TO SUPPORT POST (2), THEN LINE UP HOLES IN
INTERNAL PIN WITH SLOTS IN POST. DRIVE 3/8" ROLL PIN
(3) INTO INTERNAL PIN UNTIL GRILL BODY ROTATES FREELY.

ITEM	QTY	PART NO	DESCRIPTION
1	1	0-21-00-01	GRILL BODY ASSEMBLY
2	1	0-21-00-02	POST FOR EMBEDMENT
3	1	1-14-001	3/8" X 1 3/4" ROLL PIN



DuMor, inc.

P.O. Box 142 Mifflintown, PA 17059-0142

SCALE :

NONE

DATE DRAWN : 3/22/94

DRAWN BY : CDC

DATE REV. : 9/28/05

REV. BY : JSB

TITLE :

GRILL ASSEMBLY

REV.

B

DRAWING
NUMBER

21-00

SHEET

2 OF 2