

NOTES

- 1.) ALL STL. MEMBERS COATED W/ ZINC RICH EPOXY THEN FINISHED W/ POLYESTER POWDER COATING.

**NOTES:**

- 1.) DURING ASSEMBLY PROCEDURE;  
DO NOT COMPLETELY TIGHTEN HARDWARE.
- 2.) THE ACTUAL PARTS WILL NOT BE NUMBERED.  
NUMBERS ONLY APPLY TO DRAWING.
- 3.) UPON COMPLETION OF ASSEMBLY SQUARE  
ALL COMPONENTS THEN TIGHTEN ALL HARDWARE.
- 4.) MOUNT AND ANCHOR AS SPECIFIED.

**TOOLS REQ'D**

- 3/4" WRENCH  
5/16" ALLEN WRENCH

**PARTS LIST**

ITEM	QTY	PART NO	DESCRIPTION
1	2	0-514-30-00	STL TABLE FRAME ASSEMBLY
2	1	0-514-30-04	STL TABLE SUB FRAME
3	1	0-514-30-06	ALUM TABLE TOP
4	2	1-11-042	1/2" X 1 1/2" SS CGE BOLT
5	4	1-12-056	1/2" X 1" SS BTN SKT HD CAP SCR
6	2	1-20-015	1/2" SS NYLON LOCKNUT
7	2	1-22-015	1/2" SS FLAT WASHER

**KITS PROVIDED**

ITEM	QTY	PART NO	DESCRIPTION
8	2	K-BC0816-2W	1/2" CAP HARDWARE KIT (2PC) W/ WASHERS
9	1	K-CG0824-2L	1/2" CGE BOLT HARDWARE KIT (2PC)

① ATTACH TABLE FRAMES TOGETHER.

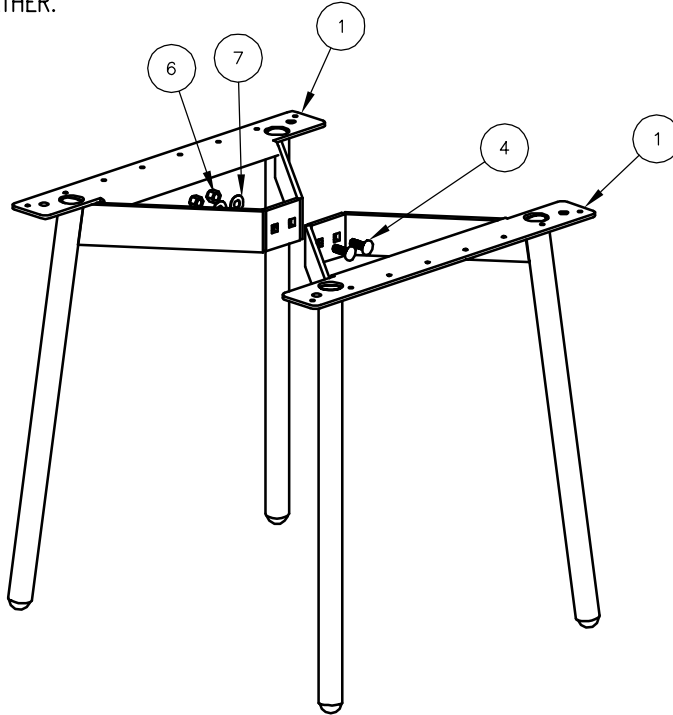

② ATTACH SUB FRAME AND TABLE TOP TO TABLE FRAME.

