

1/4" THK. STL. PLATE W/
1 1/16" Ø ANCHOR HOLE
(3-PLACES)

1 1/2" THK. (NOM.) SLATS
(SEE WOOD OPTIONS)

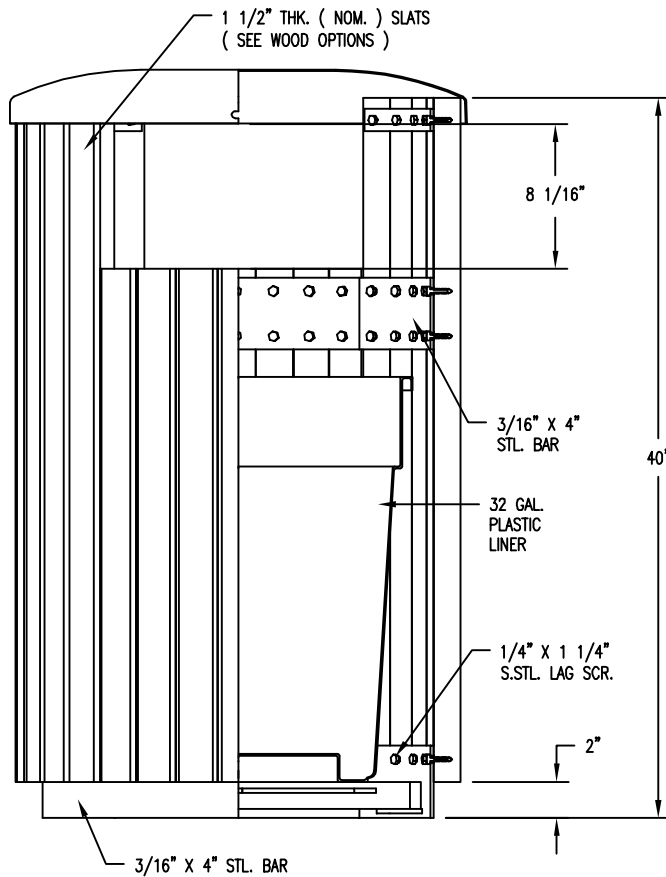

14GA SPUN
STL COVER

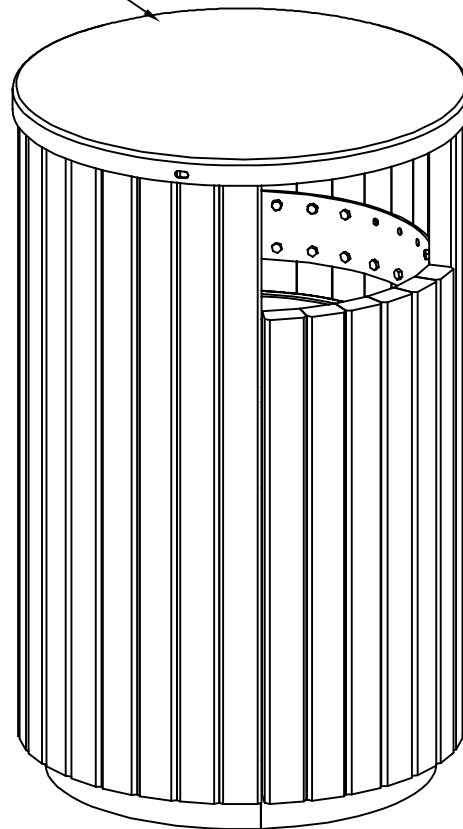

NOTES

- 1.) ALL STL. MEMBERS COATED W/ ZINC RICH EPOXY THEN FINISHED W/ BLACK POLYESTER POWDER COATING.
- 2.) 1/2" X 3 3/4" EXPANSION ANCHOR BOLTS PROVIDED.
- 3.) RECEPTACLE FULLY ASSEMBLED AT FACTORY.

SLAT OPTIONS

- "CEDAR" RECYCLED PLASTIC
- "GREY" RECYCLED PLASTIC
- "REDWOOD" RECYCLED PLASTIC
- "WALNUT" RECYCLED PLASTIC
- OTHER _____



RECEPTACLE

DATE DRAWN : 10/20/20
DRAWN BY : JSB
DATE REV. :
REV. BY :

REV.
A

DRAWING
NUMBER

70-22PL-SO
W/ CVN-30-FTC

SHEET
1 OF 2

PARTS LIST

ITEM	QTY	PART NO	DESCRIPTION
1	1	0-70-20PL-S0	20 GAL RECEPTACLE ASSEMBLY, SIDE OPENING, PL
2	1	49-22	22 GAL PL LINER W/HANDLE, BLK

TOOLS REQ'D

3/4" WRENCH
1/2" MASONRY DRILL BIT
DRILL

NOTES:

- 1.) THE ACTUAL PARTS WILL NOT BE NUMBERED. NUMBERS ONLY APPLY TO DRAWING.
- 2.) MOUNT AND ANCHOR AS SPECIFIED.

KITS PROVIDED

ITEM	QTY	PART NO	DESCRIPTION
3	1	K-ANC0860-3	1/2" X 3 3/4" SS ANCHOR KIT (3PCS)

