

NOTES

- 1.) ALL STL. MEMBERS COATED W/ ZINC RICH EPOXY THEN FINISHED W/ BLACK POLYESTER POWDER COATING.
- 2.) 1/2" X 3 3/4" EXPANSION ANCHOR BOLTS PROVIDED.

WOOD OPTIONS

- 'C' & BTR. DOUGLAS FIR KD S4S EE
- IPE S4S EE
- OTHER _____



RECEPTACLE

DATE DRAWN : 10/23/98
 DRAWN BY : AWH
 DATE REV. : 10/7/20
 REV. BY : JSB

REV.
H

DRAWING NUMBER

70-22
W/ CVN-30-FTO

SHEET
1 OF 2

PARTS LIST

ITEM	QTY	PART NO	DESCRIPTION
1	1	0-70-20	20 GAL RECEPTACLE ASSEMBLY
2	1	49-22	22 GAL PL LINER W/HANDLE, BLK

KITS PROVIDED

ITEM	QTY	PART NO	DESCRIPTION
3	1	K-ANC0860-3	1/2" X 3 3/4" SS ANCHOR KIT (3PCS)

NOTES:

- 1.) THE ACTUAL PARTS WILL NOT BE NUMBERED. NUMBERS ONLY APPLY TO DRAWING.
- 2.) MOUNT AND ANCHOR AS SPECIFIED.

TOOLS REQ'D

- 3/4" WRENCH
 PLIERS (FOR ATTACHING COVER)
 1/2" MASONRY DRILL BIT
 DRILL

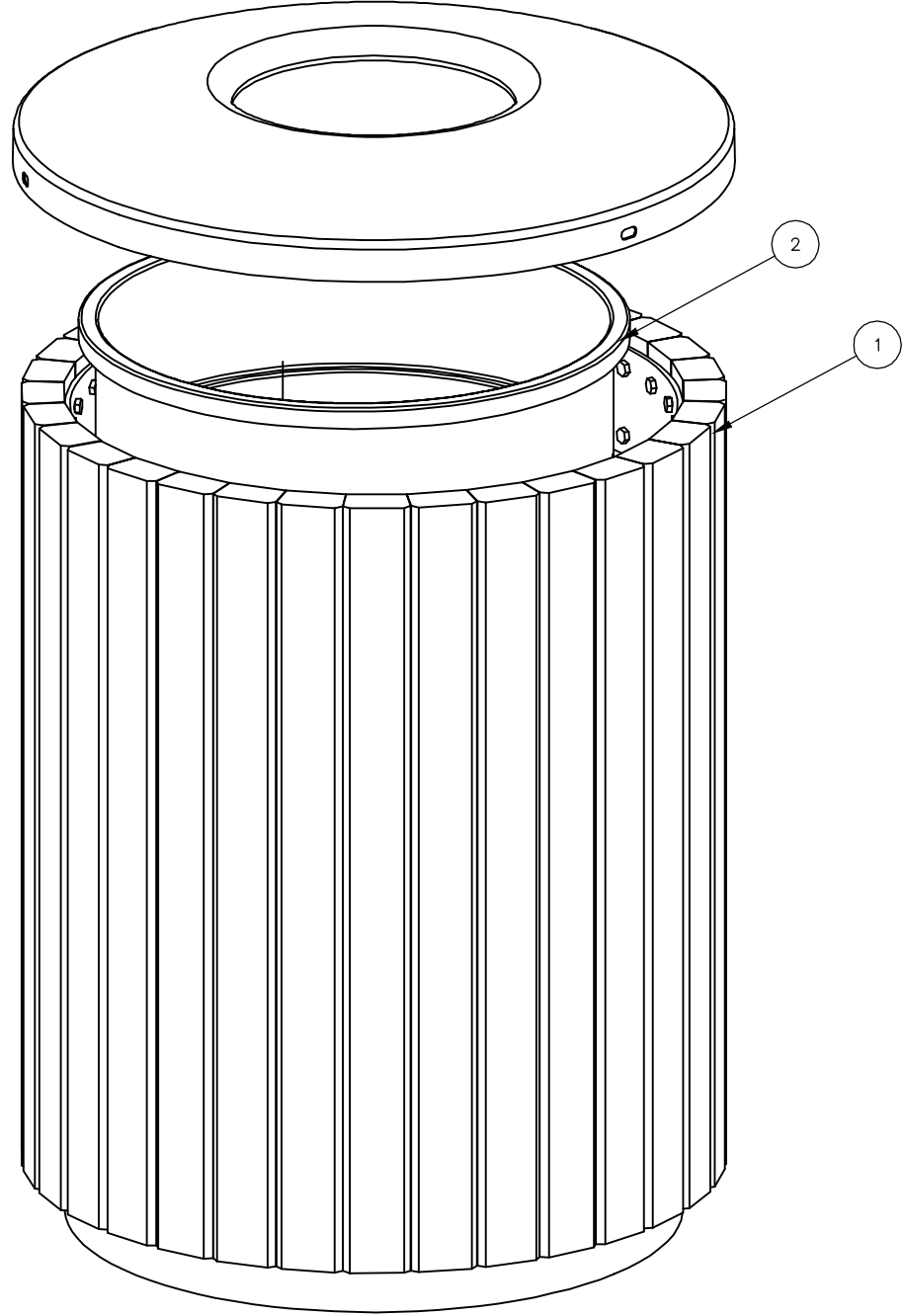

ASSEMBLY INSTRUCTIONS

DATE DRAWN : 01/03/00
 DRAWN BY : JSB
 DATE REV. : 10/7/20
 REV. BY : JSB

REV. H

DRAWING NUMBER

70-22
 W/ CVN-30-FTO

SHEET 2 OF 2