

NOTES:

- 1.) ALL STL. MEMBERS COATED W/ ZINC RICH EPOXY THEN FINISHED W/ POLYESTER POWDER COATING.
- 2.) 1/2" X 3 3/4" EXPANSION ANCHOR BOLTS PROVIDED.

SLAT OPTIONS

- "CEDAR" RECYCLED PLASTIC
- "GREY" RECYCLED PLASTIC
- "REDWOOD" RECYCLED PLASTIC
- "WALNUT" RECYCLED PLASTIC
- OTHER _____



BENCH

DATE DRAWN : 10/08/15
 DRAWN BY : RDH
 DATE REV. :
 REV. BY :

REV.
A

DRAWING
NUMBER

492-60PL

SHEET
1 OF 2

NOTES:

- 1.) DURING ASSEMBLY PROCEDURE;
DO NOT COMPLETELY TIGHTEN HARDWARE.
- 2.) THE ACTUAL PARTS WILL NOT BE NUMBERED.
NUMBERS ONLY APPLY TO DRAWING.
- 3.) UPON COMPLETION OF ASSEMBLY SQUARE
ALL COMPONENTS THEN TIGHTEN ALL HARDWARE.
- 4.) MOUNT AND ANCHOR AS SPECIFIED.

TOOLS REQ'D

- 3/4" WRENCH
- 1/2" WRENCH
- 5/16" ALLEN WRENCH
- 1/4" ALLEN WRENCH
- 3/16" ALLEN WRENCH
- 1/2" MASONRY DRILL BIT
- DRILL

PARTS LIST

| ITEM | QTY | PART NO | DESCRIPTION |
|------|-----|---------------|--------------------------------------|
| 1 | 5 | 0-143-60PL-01 | 2" X 3" X 71" INT'R SLAT, PLASTIC |
| 2 | 2 | 0-143-60PL-02 | 2" X 3" X 71" PLASTIC EDGE SLAT |
| 3 | 2 | 0-16-60-06 | 71" SEAT BRACE |
| 4 | 2 | 0-492-00-01 | CAST ALUM BKLS BENCH SUPPORT, NO ARM |
| 5 | 1 | 0-57-60-04 | 71 3/4" PIPE BRACE |
| 6 | 2 | 0-91-00-03 | CENTER STRAP |
| 7 | 2 | 0-91-00-04 | END CONTOUR STRAP |
| 8 | 6 | 1-12-065 | 1/2" X 2 1/2" FLT SKT HD CAP SCR |
| 9 | 8 | 1-12-116 | 5/16" X 1" SS BTN SKT HD CAP SCR |
| 10 | 28 | 1-13-023 | 5/16" X 1 1/4" SS BTN SKT HD LAG |
| 11 | 8 | 1-20-016 | 5/16" SS NYLON LOCKNUT |
| 12 | 44 | 1-22-017 | 5/16" SS FLAT WASHER |

KITS PROVIDED

| ITEM | QTY | PART NO | DESCRIPTION |
|------|-----|-------------|-----------------------------------|
| 13 | 1 | K-147-60 | 147-60 SER HARDWARE KIT |
| 14 | 1 | K-ANC0860-4 | 1/2" X 3 3/4" SS ANCHOR KIT (4PC) |
| 15 | 1 | K-FC0840-6 | 1/2" CAP HARDWARE KIT (6PC) |

1 ATTACH CAST IRON BENCH SUPPORTS TO PIPE BRACE, ATTACH END CONTOUR STRAPS

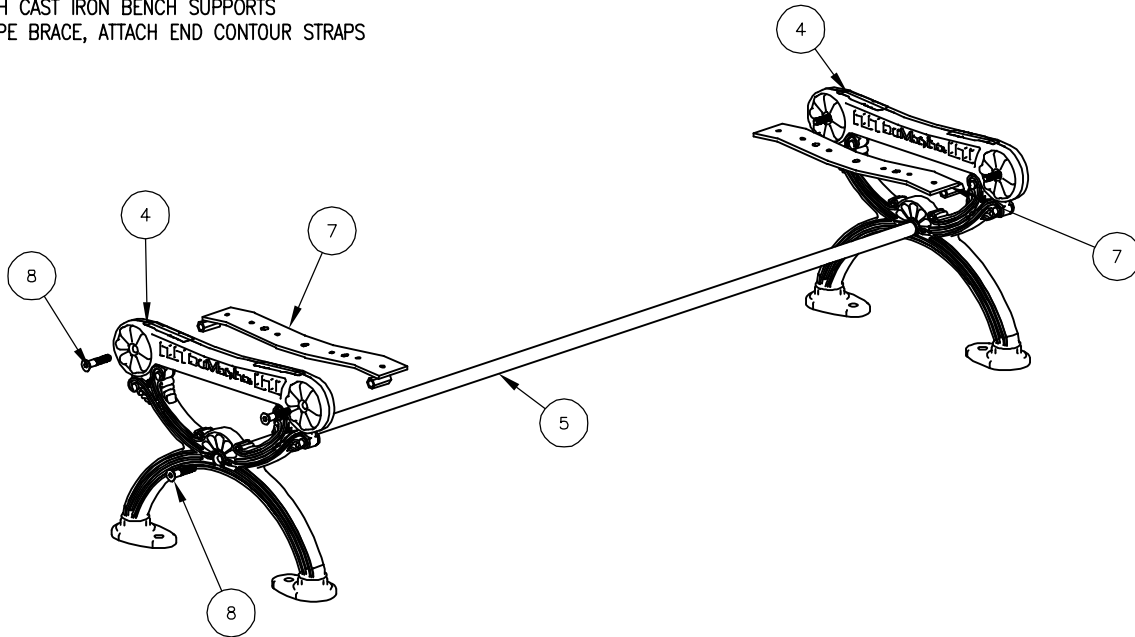

2 ATTACH CENTER CONTOUR STRAPS & SEAT BRACES TO STEP 1 THROUGH SLOTTED HOLES.

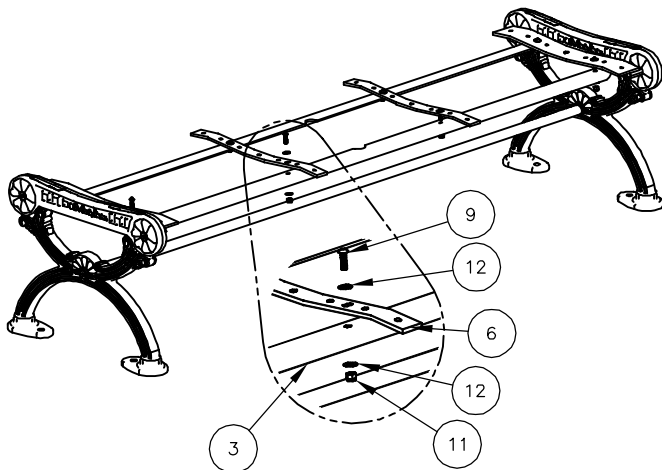

3 ATTACH SLATS TO STEP 2.

