

NOTES:

- 1.) ALL STL. MEMBERS COATED W/ ZINC RICH EPOXY THEN FINISHED W/ POLYESTER POWDER COATING.
- 2.) 1/2" X 2 1/2" NYLON GLIDES AND 1/2" X 5 1/2" EXPANSION ANCHOR BOLTS PROVIDED.

NOTE:

- 1.) DURING ASSEMBLY PROCEDURE;
DO NOT COMPLETELY TIGHTEN HARDWARE.
- 2.) THE ACTUAL PARTS WILL NOT BE NUMBERED.
NUMBERS ONLY APPLY TO DRAWING.
- 3.) UPON COMPLETION OF ASSEMBLY SQUARE
ALL COMPONENTS THEN TIGHTEN ALL HARDWARE.
- 4.) MOUNT AND ANCHOR AS SPECIFIED.

TOOLS REQ'D

- 3/4" WRENCH
- 9/16" WRENCH
- 1/2" WRENCH
- 1/2" MASONRY DRILL BIT
DRILL

PARTS LIST

ITEM	QTY	PART NO	DESCRIPTION
1	6	0-101-00-05	PIPE CLAMP (101)
2	1	0-101-60-15	STL SUPPORT FOR 6 SEAT TABLE
3	6	0-294-00-01	SUPPORT FRAME / 1-SEAT
4	6	0-294-00-03HS	16" STL SEAT
5	1	0-294-60-05	TABLE TOP FOR 6 SEATS
6	12	1-11-032	5/16" X 1" SS CGE BOLT
7	18	1-11-042	1/2" X 1 1/2" SS CGE BOLT
8	18	1-20-015	1/2" SS NYLON LOCKNUT
9	12	1-20-016	5/16" SS NYLON LOCKNUT
10	6	1-21-019	1/2" SS HEX ACORN NUT
11	18	1-22-015	1/2" SS FLAT WASHER
12	12	1-22-017	5/16" SS FLAT WASHER
13	6	5-48-077	1/2" X 2 1/2" GLIDE

KITS PROVIDED

ITEM	QTY	PART NO	DESCRIPTION
14	2	K-ANC0888-3	1/2" X 5 1/2" SS ANCHOR KIT (3PC)
15	1	K-CG0516-12L	5/16" CGE BOLT HARDWARE KIT (12PC)
16	5	K-CG0824-4L	1/2" CGE BOLT HARDWARE KIT (4)
17	2	K-GL0840-3A	1/2" X 2 1/2" GLIDE KIT W/ ACORN NUT (3PC)

- ① ATTACH FRAMES TOGETHER. ATTACH GLIDES, UNLESS ANCHORING.

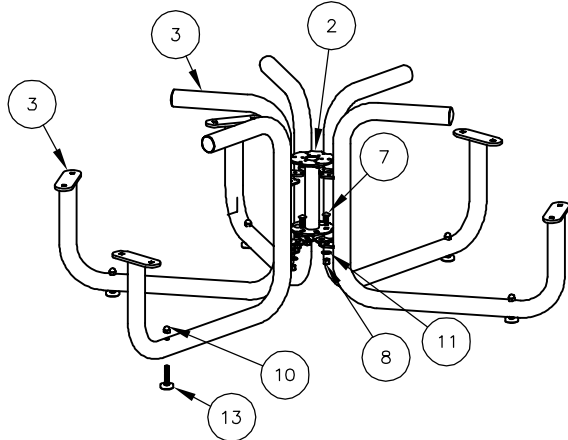

- ② ATTACH TABLE TOP TO STEP 1.

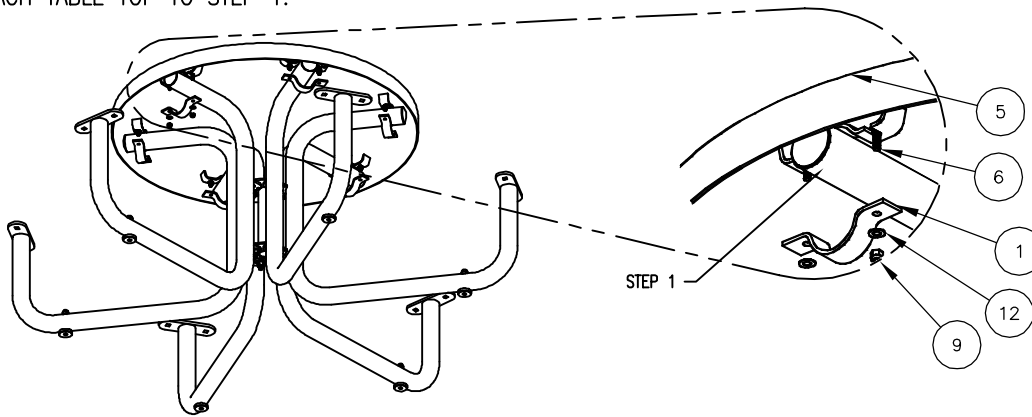

- ③ ATTACH SEAT TO STEP 2.

