

PARTS LIST

ITEM	QTY	PART NO	DESCRIPTION
1	1	0-126-05	TABLE TOP WITH BOLT TABS
2	16	0-460-00-02	CONTOUR STRAP
3	4	0-462-00-01	STL TABLE SUPPORT FRAME, 1 SEAT
4	1	0-462-00-02	3/8" THK STL BOLT PLATE
5	16	0-462-00-04	15 3/4" ALUM EXTRUSION
6	24	0-462-00TX-05	2" X 3" X 15" SLAT, TX
7	4	0-463-00-03L	LEFT STL SEAT FRAME
8	4	0-463-00-03R	RIGHT STL SEAT FRAME
9	4	1-11-003	3/8" X 1 1/2" SS CGE BOLT
10	16	1-11-042	1/2" X 1 1/2" SS CGE BOLT
11	32	1-12-053	5/16" X 1 1/2" SS BTN SKT HD CAP SCR
12	48	1-13-023	5/16" X 1 1/2" SS BTN SKT HD LAG
13	4	1-20-007	3/8" SS NYLON LOCKNUT
14	16	1-20-015	1/2" SS NYLON LOCKNUT
15	16	1-22-015	1/2" SS FLAT WASHER
16	48	1-22-017	5/16" SS FLAT WASHER
17	4	1-22-024	3/8" SS FLAT WASHER

NOTES:

- 1.) DURING ASSEMBLY PROCEDURE; DO NOT COMPLETELY TIGHTEN HARDWARE.
- 2.) THE ACTUAL PARTS WILL NOT BE NUMBERED. NUMBERS ONLY APPLY TO DRAWING.
- 3.) UPON COMPLETION OF ASSEMBLY SQUARE ALL COMPONENTS THEN TIGHTEN ALL HARDWARE.
- 4.) MOUNT AND ANCHOR AS SPECIFIED.

TOOLS REQ'D

- 3/4" WRENCH
- 9/16" WRENCH
- 1/4" ALLEN WRENCH
- 3/16" ALLEN WRENCH
- 1/2" MASONRY DRILL BIT DRILL

KITS PROVIDED

ITEM	QTY	PART NO	DESCRIPTION
18	1	K-ANC0860-4	1/2" X 3 3/4" SS ANCHOR KIT (4PC)
19	4	K-BC0524-8	5/16" CAP HARDWARE KIT (8PC)
20	2	K-BL0524-24	5/16" LAG HARDWARE KIT (24PC)
21	1	K-CG0624-4L	3/8" CGE BOLT HARDWARE KIT (4PC)
22	4	K-CG0824-4L	1/2" CGE BOLT HARDWARE KIT (4)

① ATTACH 4 SUPPORTS TOGETHER.

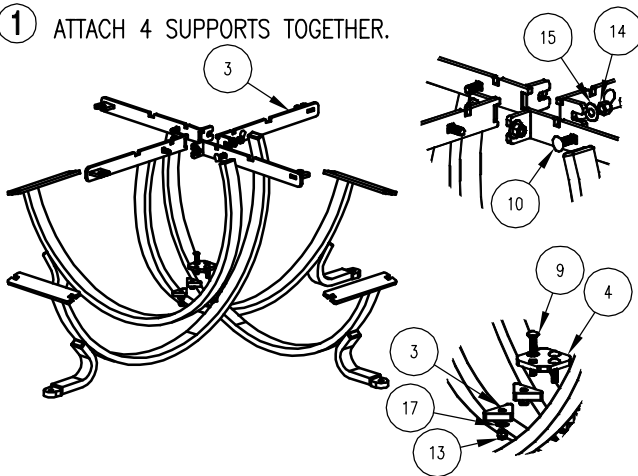

② ATTACH TABLE TOP TO STEP 1.

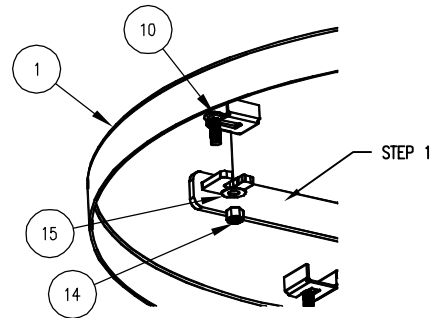

③ ATTACH SLATS TO CONTOUR STRAPS.

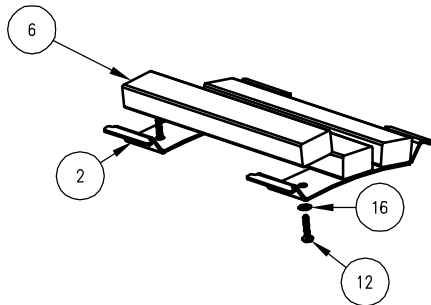

④ ATTACH ALUM. EXTRUSION TO LEFT & RIGHT SEAT FRAMES, ENSURE PINS ARE IN "L" SLOTS. ATTACH TO STEP 1.

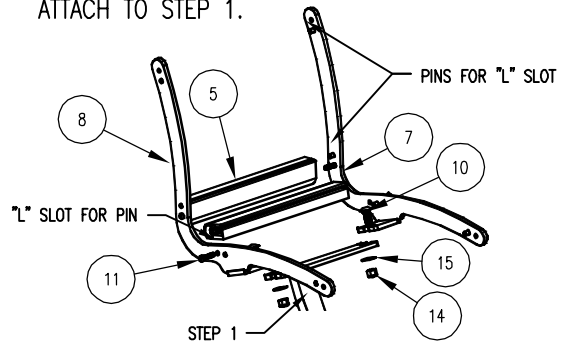

⑤ INSERT STEP 3 INTO STEP 4, USING SLOT ON ALUM. EXTRUSION.

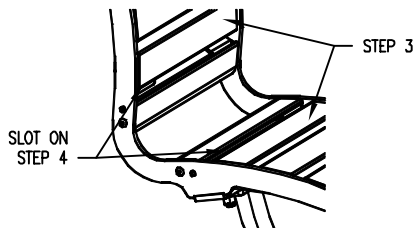

⑥ ATTACH REMAINING ALUM. EXTRUSIONS TO SEAT FRAMES, AS IN STEP 4.

