

NOTES

- 1.) ALL STL. MEMBERS COATED W/ ZINC RICH EPOXY THEN FINISHED W/ POLYESTER POWDER COATING.
- 2.) 1/2" X 3 3/4" EXPANSION ANCHOR BOLTS PROVIDED.

SLAT OPTIONS

- ANTIQUE MAHOGANY TEXTURED
- BRAZILIAN WALNUT TEXTURED
- OTHER _____



PICNIC TABLE

DATE DRAWN : 11/09/18
 DRAWN BY : RDH
 DATE REV. :
 REV. BY :

REV.
A

DRAWING NUMBER

464-68TX

SHEET
1 OF 2

NOTES:

- 1.) DURING ASSEMBLY PROCEDURE;
DO NOT COMPLETELY TIGHTEN HARDWARE.
- 2.) THE ACTUAL PARTS WILL NOT BE NUMBERED.
NUMBERS ONLY APPLY TO DRAWING.
- 3.) UPON COMPLETION OF ASSEMBLY SQUARE
ALL COMPONENTS THEN TIGHTEN ALL HARDWARE.
- 4.) MOUNT AND ANCHOR AS SPECIFIED.

TOOLS REQ'D

- 3/4" WRENCH
- 3/16" ALLEN WRENCH
- 1/2" MASONRY DRILL BIT
- DRILL

PARTS LIST

ITEM	QTY	PART NO	DESCRIPTION
1	6	0-143-60TX-01	2" X 3" X 71" INT'R SLAT, TX
2	8	0-460-00-02	CONTOUR STRAP
3	4	0-460-60-03	71 3/4" ALUM EXTRUSION
4	1	0-464-00-01	TABLE SUPPORT
5	4	0-464-00-02	TABLE CONTOUR STRAP
6	1	0-464-68-01	WHLCHR TABLE SUPPORT
7	1	0-464-68-04	WHLCHR TABLE END PLATE
8	1	0-464-68L-06	95 3/4" LEFT ALUM EXTRUSION FOR WHLCHR TABLE
9	1	0-464-68R-06	95 3/4" RIGHT ALUM EXTRUSION FOR WHLCHR TABLE
10	8	0-464-68TX-05	2" X 3" X 95" SLAT, TX
11	12	1-12-053	5/16" X 1 1/2" SS BTN SKT HD CAP SCR
12	4	1-12-116	5/16" X 1" SS BTN SKT HD CAP SCR
13	56	1-13-023	5/16" X 1 1/2" SS BTN SKT HD LAG
14	56	1-22-017	5/16" SS FLAT WASHER

KITS PROVIDED

ITEM	QTY	PART NO	DESCRIPTION
15	1	K-ANC0860-4	1/2" X 3 3/4" SS ANCHOR KIT (4PC)
16	1	K-BC0516-4	5/16" CAP HARDWARE KIT (4PC)
17	2	K-BC0524-6	5/16" CAP HARDWARE KIT (6PC)
18	1	K-BL0524-56	5/16" LAG HARDWARE KIT (56PC)

1 ATTACH SLATS TO CONTOUR STRAPS.

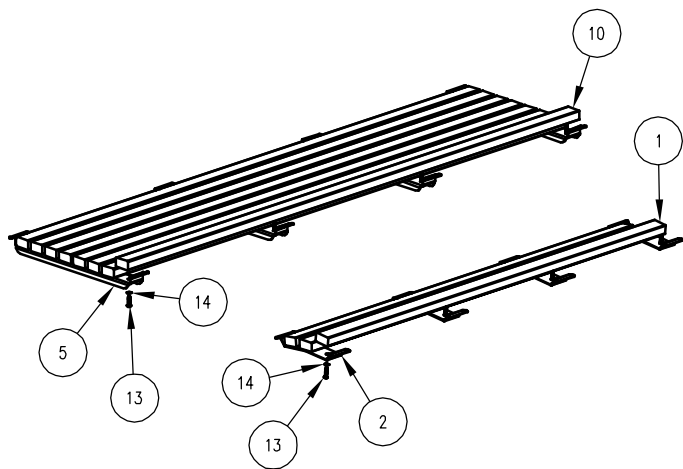

2 ATTACH 3 ALUM. EXTRUSIONS AS SHOWN, TO LEFT & RIGHT TABLE SUPPORTS, ENSURE PINS ARE IN "L" SLOTS.

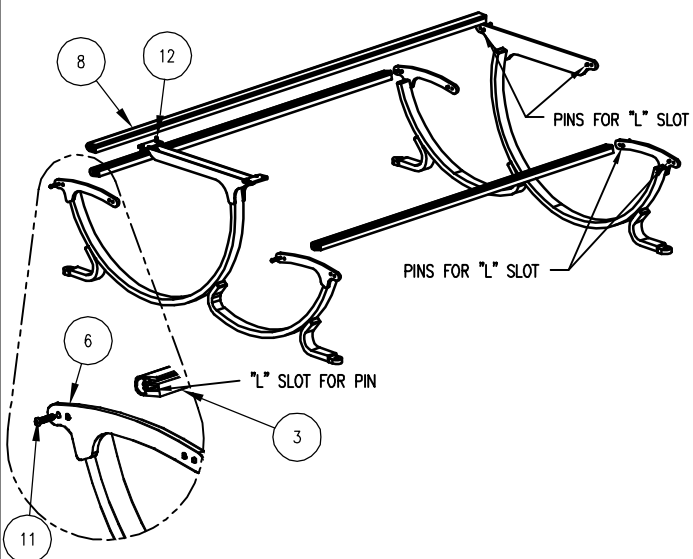

3 INSERT STEP 1 INTO STEP 2, USING SLOTS ON ALUM. EXTRUSION.

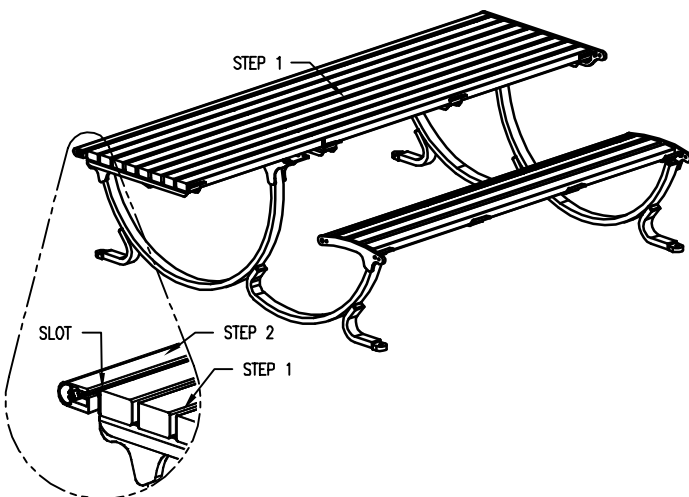

4 ATTACH 3 REMAINING ALUM. EXTRUSIONS & END PLATE TO SUPPORTS, AS IN STEP 2. UPON COMPLETION OF TABLE ASSEMBLY SQUARE ALL COMPONENTS THEN TIGHTEN ALL HARDWARE.

