

SLAT OPTIONS

- ANTIQUE MAHOGANY TEXTURED
- BRAZILIAN WALNUT TEXTURED
- OTHER \_\_\_\_\_

NOTES:

- 1.) ALL STL. MEMBERS COATED W/ ZINC RICH EPOXY THEN FINISHED W/ POLYESTER POWDER COATING.
- 2.) 1/2" X 3 3/4" EXPANSION ANCHOR BOLTS PROVIDED.



BENCH

DATE DRAWN : 11/09/18  
 DRAWN BY : ESS  
 DATE REV. :  
 REV. BY :

REV.  
A

DRAWING  
NUMBER

91-80TX

SHEET  
1 OF 2

**NOTES:**

- 1.) DURING ASSEMBLY PROCEDURE;  
DO NOT COMPLETELY TIGHTEN HARDWARE.
- 2.) THE ACTUAL PARTS WILL NOT BE NUMBERED.  
NUMBERS ONLY APPLY TO DRAWING.
- 3.) UPON COMPLETION OF ASSEMBLY SQUARE  
ALL COMPONENTS THEN TIGHTEN ALL HARDWARE.
- 4.) MOUNT AND ANCHOR AS SPECIFIED.

**TOOLS REQ'D**

- 3/4" WRENCH
- 1/2" WRENCH
- 5/16" ALLEN WRENCH
- 1/4" ALLEN WRENCH
- 3/16" ALLEN WRENCH
- 1/2" MASONRY DRILL BIT
- DRILL

**PARTS LIST**

ITEM	QTY	PART NO	DESCRIPTION
1	10	0-143-40TX-01	2" X 3" X 47" INT'R SLAT, TX
2	4	0-143-40TX-02	2" X 3" X 47" EDGE SLAT, TX
3	4	0-16-40-06	47" SEAT BRACE
4	1	0-57-40-04	47 3/4" PIPE BRACE
5	1	0-57-40-05	47 3/4" PIPE BRACE WITH STUD
6	3	0-91-00-02	BKLESS CAST IRON BNCH SUPT
7	2	0-91-00-03	CENTER STRAP
8	3	0-91-00-04	END CONTOUR STRAP
9	1	0-91-00-05	END STRAP FOR CENTER LEG
10	2	1-12-040	1/2" X 5 1/2" SS HEX HD CAP SCR
11	6	1-12-065	1/2" X 2 1/2" FLT SKT HD CAP SCR
12	12	1-12-116	5/16" X 3 3/4" SS BTN SKT HD CAP SCR
13	42	1-13-023	5/16" X 1 1/2" SS BTN SKT HD LAG
14	12	1-20-016	5/16" SS NYLON LOCKNUT
15	66	1-22-017	5/16" SS FLAT WASHER

**KITS PROVIDED**

ITEM	QTY	PART NO	DESCRIPTION
16	2	K-147-40	147-40 SER HARDWARE KIT
17	2	K-ANC0860-3	1/2" X 3 3/4" SS ANCHOR KIT (3PCS)
18	1	K-FC0840-6	1/2" CAP HARDWARE KIT (6PC)
19	1	K-HC0888-2	1/2" CAP HARDWARE KIT (2PC)

**1** ATTACH CAST BENCH SUPPORTS TO PIPE BRACES, ATTACH END & CENTER CONTOUR STRAPS

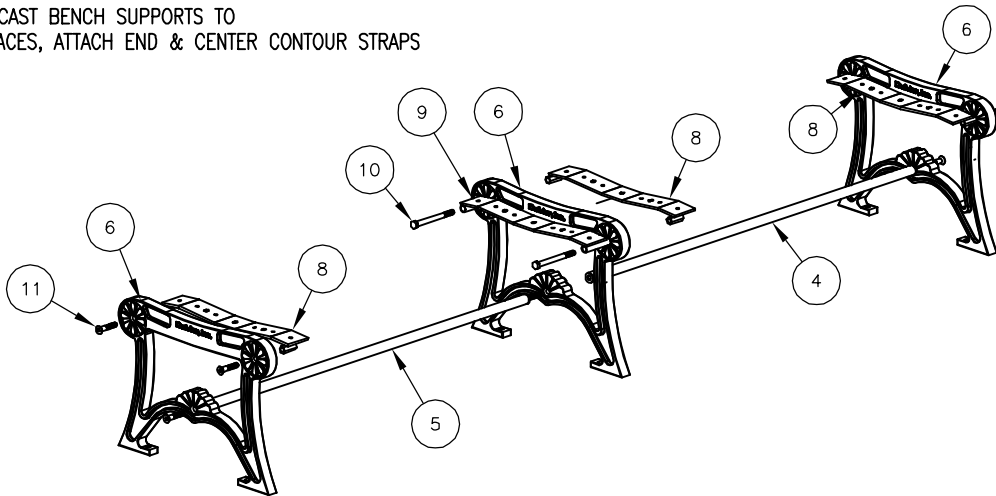

**2** ATTACH CENTER CONTOUR STRAPS & SEAT BRACES TO STEP 1 THROUGH SLOTTED HOLES.

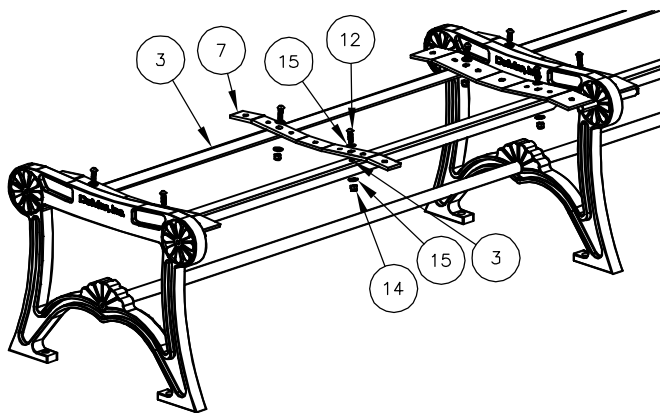

**3** ATTACH SLATS TO STEP 2.

