

NOTES:

- 1.) ALL STL. MEMBERS COATED W/ ZINC RICH EPOXY THEN FINISHED W/ POLYESTER POWDER COATING.
- 2.) 1/2" X 2 1/2" NYLON GLIDES AND 1/2" X 5 1/2" EXPANSION ANCHOR BOLTS PROVIDED.

NOTE:

- 1.) DURING ASSEMBLY PROCEDURE;
DO NOT COMPLETELY TIGHTEN HARDWARE.
- 2.) THE ACTUAL PARTS WILL NOT BE NUMBERED.
NUMBERS ONLY APPLY TO DRAWING.
- 3.) UPON COMPLETION OF ASSEMBLY SQUARE
ALL COMPONENTS THEN TIGHTEN ALL HARDWARE.
- 4.) MOUNT AND ANCHOR AS SPECIFIED.

TOOLS REQ'D

- 3/4" WRENCH
- 9/16" WRENCH
- 1/2" WRENCH
- 1/2" MASONRY DRILL BIT
- DRILL

PARTS LIST

ITEM	QTY	PART NO	DESCRIPTION
1	1	0-101-00-01	42" DIA STL TABLE TOP
2	3	0-101-00-05	PIPE CLAMP (101)
3	1	0-294-00-01	SUPPORT FRAME / 1-SEAT
4	1	0-294-00-02L	SUPPORT FRAME / 1-SEAT LEFT FOR ADA
5	1	0-294-00-02R	SUPPORT FRAME / 1-SEAT RIGHT FOR ADA
6	3	0-294-00-03HS	16" STL SEAT
7	1	0-294-00-06	STL SUPPORT FOR 3 SEAT TABLE
8	8	1-11-032	5/16" X 1" SS CGE BOLT
9	12	1-11-042	1/2" X 1 1/2" SS CGE BOLT
10	12	1-20-015	1/2" SS NYLON LOCKNUT
11	8	1-20-016	5/16" SS NYLON LOCKNUT
12	5	1-21-019	1/2" SS HEX ACORN NUT
13	12	1-22-015	1/2" SS FLAT WASHER
14	8	1-22-017	5/16" SS FLAT WASHER
15	5	5-48-077	1/2" X 2 1/2" GLIDE

KITS PROVIDED

ITEM	QTY	PART NO	DESCRIPTION
16	1	K-ANC0888-1	1/2" X 5 1/2" SS ANCHOR KIT (1PC)
17	1	K-ANC0888-4	1/2" X 5 1/2" SS ANCH KIT (4PCS)
18	1	K-CG0516-8L	5/16" CGE BOLT HARDWARE KIT (8PC)
19	3	K-CG0824-4L	1/2" CGE BOLT HARDWARE KIT (4)
20	1	K-GL0840-5A	1/2" X 2 1/2" GLIDE KIT W/ ACORN NUT (5PC)

① ATTACH FRAMES TOGETHER. ATTACH GLIDES, UNLESS ANCHORING.

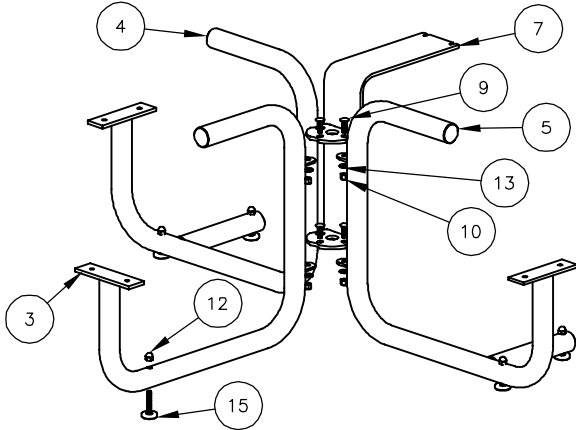

② ATTACH TABLE TOP TO STEP 1.

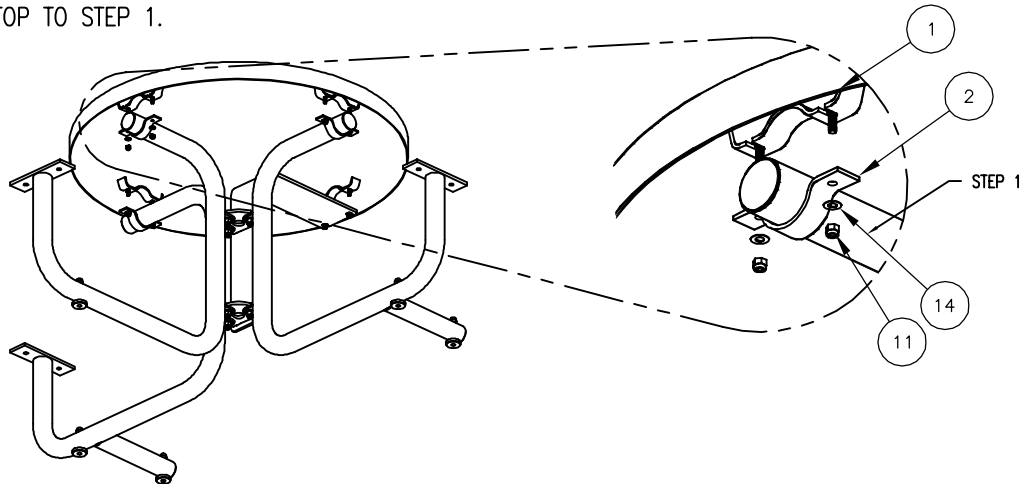

③ ATTACH SEAT TO STEP 2.

