

FINISH OPTIONS:

- ALL STL. MEMBERS COATED W/ ZINC RICH EPOXY THEN FINISHED W/ POLYESTER POWDER COATING.
- HOT DIP GALV. AFTER FABRICATION.

LENGTH OPTIONS

- 6' TABLE
- 8' TABLE

NOTES:

1.) 1/2" X 3 3/4" EXPANSION ANCHORS PROVIDED.



PICNIC TABLE

DATE DRAWN : 3/22/94
 DRAWN BY : CDC
 DATE REV. : 01/12/17
 REV. BY : RDH

REV.
H

DRAWING
NUMBER

77 SERIES A

SHEET
1 OF 2

NOTES:

- 1.) DURING ASSEMBLY PROCEDURE;
DO NOT COMPLETELY TIGHTEN HARDWARE.
- 2.) THE ACTUAL PARTS WILL NOT BE NUMBERED.
NUMBERS ONLY APPLY TO DRAWING.
- 3.) UPON COMPLETION OF ASSEMBLY SQUARE
ALL COMPONENTS THEN TIGHTEN ALL HARDWARE.
- 4.) MOUNT AND ANCHOR AS SPECIFIED.

TOOLS REQ'D

- 1/2" WRENCH
- 3/4" WRENCH

PARTS LIST

ITEM	QTY	PART NO	DESCRIPTION
1	5	0-71-60A	2" X 10" X 6' ALUM. PLANK ASSEMBLY
2	2	0-77-00-01	END SUPPORT FRAME
3	1	0-77-00-03	CENTER/END CHANNEL
4	2	0-77-60-02	DIAGONAL BRACE FOR 6' TABLE
5	26	1-11-032	5/16" X 1" SS CGE BOLT
6	4	1-12-061	5/16" X 1" SS HEX HD CAP SCR
7	4	1-20-016	5/16" SS NYLON LOCKNUT
8	26	1-21-015	5/16" SS HEX NUT
9	34	1-22-017	5/16" SS FLAT WASHER
10	26	5-48-702	ALUMINUM CLIP

KITS PROVIDED

ITEM	QTY	PART NO	DESCRIPTION
11	1	K-77A	77A HARDWARE KIT
12	1	K-ALUMCLIP-26	ALUMINUM CLIP, 26 PCS
13	1	K-ANCO860-4	1/2" X 3 3/4" SS ANCHOR KIT (4PC)

1 ATTACH SUPPORT FRAMES TO ALUMINUM SLATS

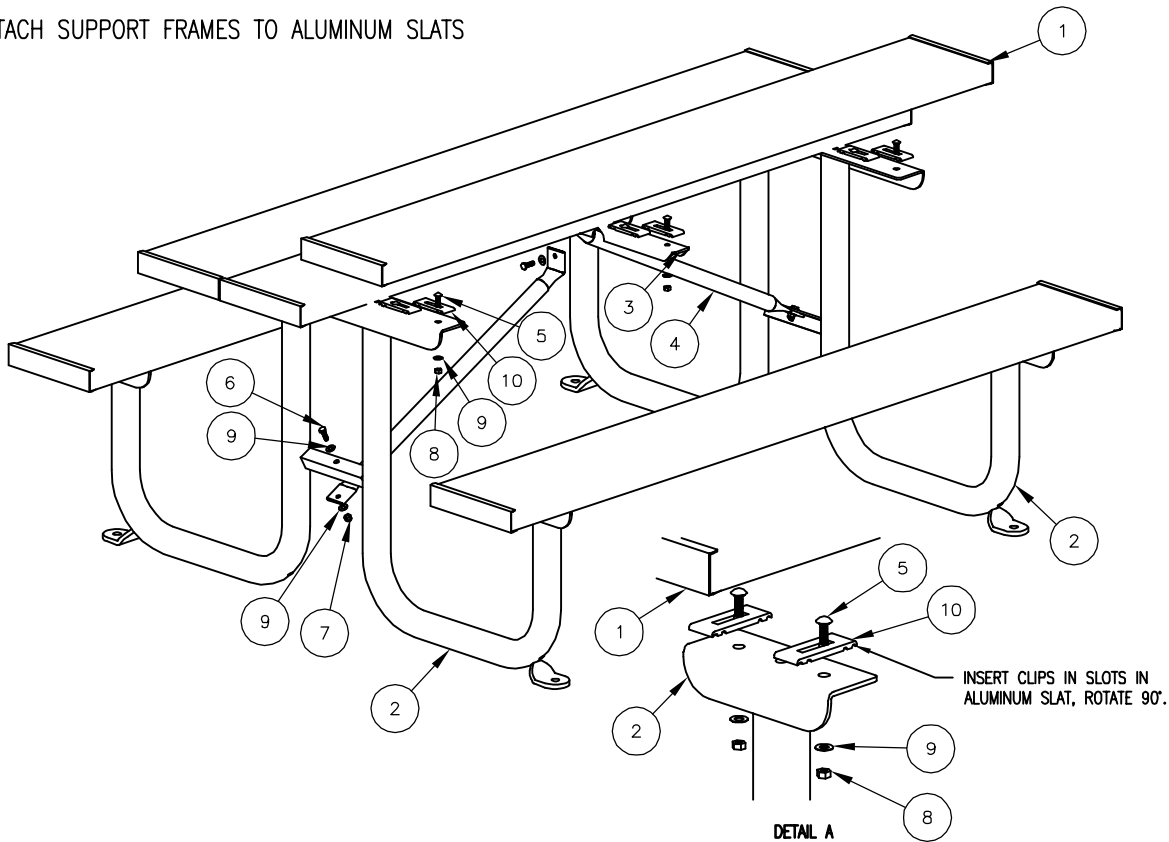

2 ATTACH DIAGONAL BRACES TO STEP 1 ASSEMBLY.

