

S-2 SURFACE

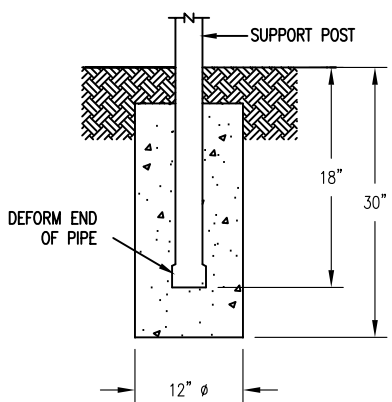

S-1 EMBEDMENT

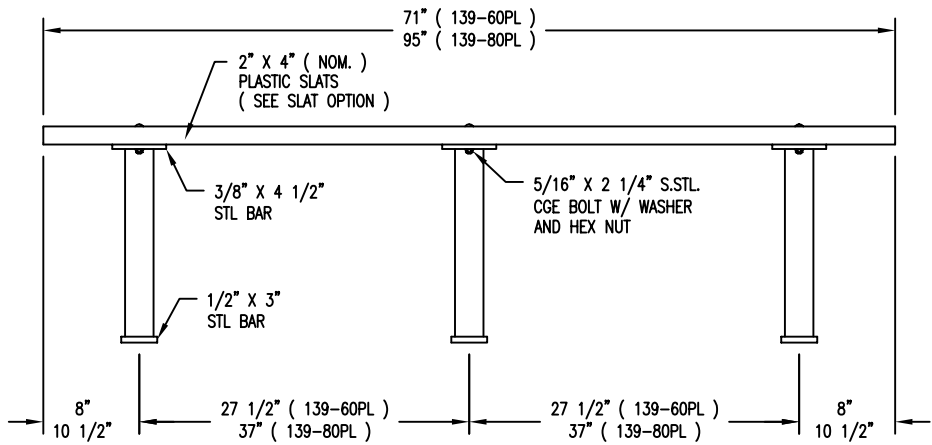
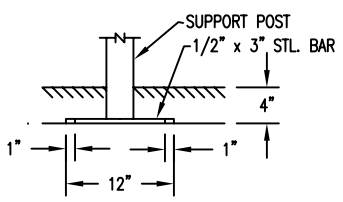

S-4 SUB FLOOR

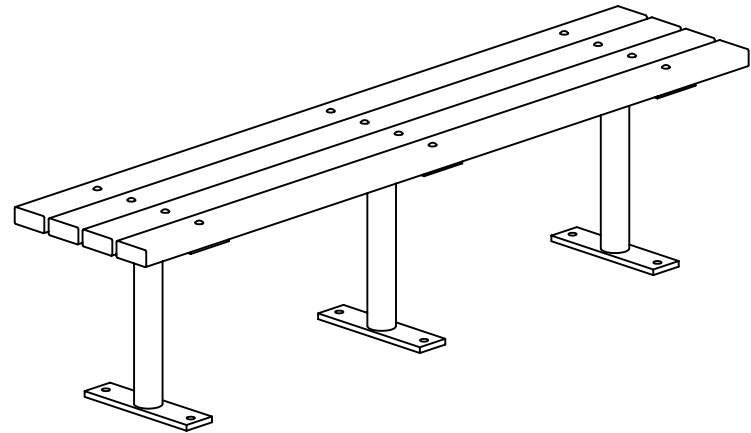

LENGTH OPTIONS

- 6' BENCH
- 8' BENCH

SLAT OPTIONS

- "CEDAR" RECYCLED PLASTIC
- "GREY" RECYCLED PLASTIC
- "REDWOOD" RECYCLED PLASTIC
- "WALNUT" RECYCLED PLASTIC
- OTHER _____

NOTES

- 1.) ALL STL. MEMBERS COATED W/ ZINC RICH EPOXY THEN FINISHED W/ POLYESTER POWDER COATING.
- 2.) 1/2" X 3 3/4" EXPANSION ANCHOR BOLTS PROVIDED FOR S-2 & S-4 OPTIONS.

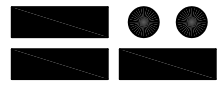
 DuMor, inc. P.O. Box 142 Mifflintown, PA 17059-0142	SCALE :	NONE	TITLE :		BENCH	
	DATE DRAWN :	9/20/01	REV.	DRAWING NUMBER	139 SERIES PL	
	DRAWN BY :	AWH	C			
	DATE REV. :	10/26/11				
REV. BY :	JSB	SHEET		1 OF 2		

SURFACE MOUNT
S-2 OPTION SHOWN

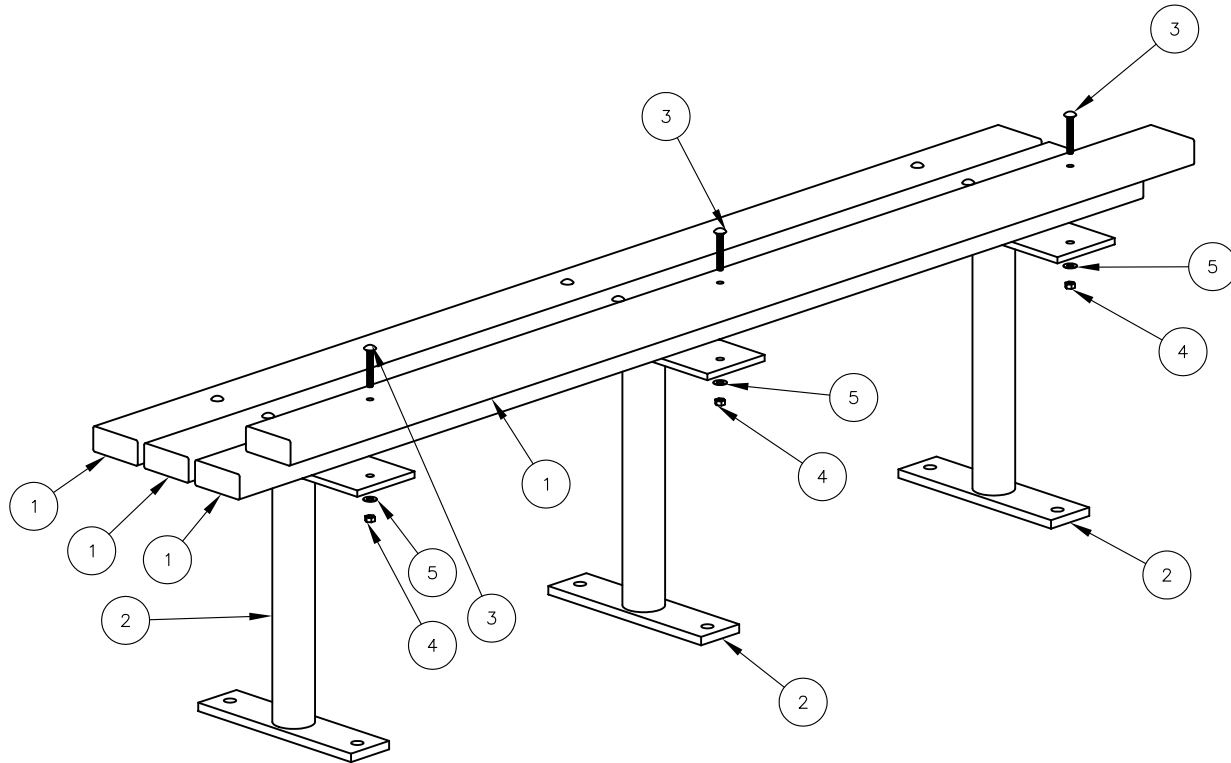

NOTE:

- 1.) DURING ASSEMBLY PROCEDURE;
DO NOT COMPLETELY TIGHTEN HARDWARE.
- 2.) THE ACTUAL PARTS WILL NOT BE NUMBERED;
NUMBERS ONLY APPLY TO DRAWING.
- 3.) SEE SPEC. SHEET 1 FOR MOUNTING OPTIONS.

STEP 1:

- USE 4 - PCS. 2" X 4" X 71" PLASTIC SLAT (1)
- 3 - PCS. SUPPORT POST (2)
- 12 - PCS. 5/16" X 2 1/4" SS CGE BOLT (3)
- 12 - PCS. 5/16" SS HEX NUT (4)
- 12 - PCS. 5/16" SS FLAT WASHER (5)

ATTACH ONE PLASTIC SLAT (1) TO THREE SUPPORT POSTS (2) USING HARDWARE (3, 4 & 5). TIGHTEN TO SNUG FIT. REPEAT UNTIL ALL PLASTIC SLATS ARE ATTACHED TO SUPPORT POSTS.

STEP 2:

UPON COMPLETION OF BENCH ASSEMBLY SQUARE ALL COMPONENTS THEN TIGHTEN ALL HARDWARE.

STEP 3:

ANCHOR ACCORDING TO SUPPORT OPTION USED.

ITEM	QTY	PART NO	DESCRIPTION
1	4	0-138-60PL-02	2" X 4" X 71" RECYCLED PLASTIC SLAT
2	3	0-139-01/S-2	SUPPORT FOR SURFACE MT
3	12	1-11-062	5/16" X 2 1/4" SS CGE BOLT
4	12	1-21-015	5/16" SS HEX NUT
5	12	1-22-017	5/16" SS FLAT WASHER



DuMor, inc.
P.O. Box 142 Mifflintown, PA 17059-0142

SCALE : NONE
DATE DRAWN : 9/20/01
DRAWN BY : AWH
DATE REV. : 12/2/09
REV. BY : JSB

TITLE : BENCH ASSEMBLY

REV. B	DRAWING NUMBER 139 SERIES PL	SHEET 2 OF 2
--------	------------------------------	--------------