

NOTES:

- 1.) ALL STL. MEMBERS COATED W/ ZINC RICH EPOXY THEN FINISHED W/ POLYESTER POWDER COATING.
- 2.) 1/2" X 3 3/4" EXPANSION ANCHOR BOLTS PROVIDED.
- 3.) BENCH IS SHIPPED UNASSEMBLED.

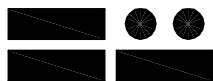

DuMor, inc.
P.O. Box 142 Mifflintown, PA 17059-0142

SCALE :	NONE
DATE DRAWN :	8/17/11
DRAWN BY :	JSB
DATE REV. :	
REV. BY :	

TITLE :	BENCH		
REV.	DRAWING NUMBER	427-45/S-5	SHEET
A			1 OF 2

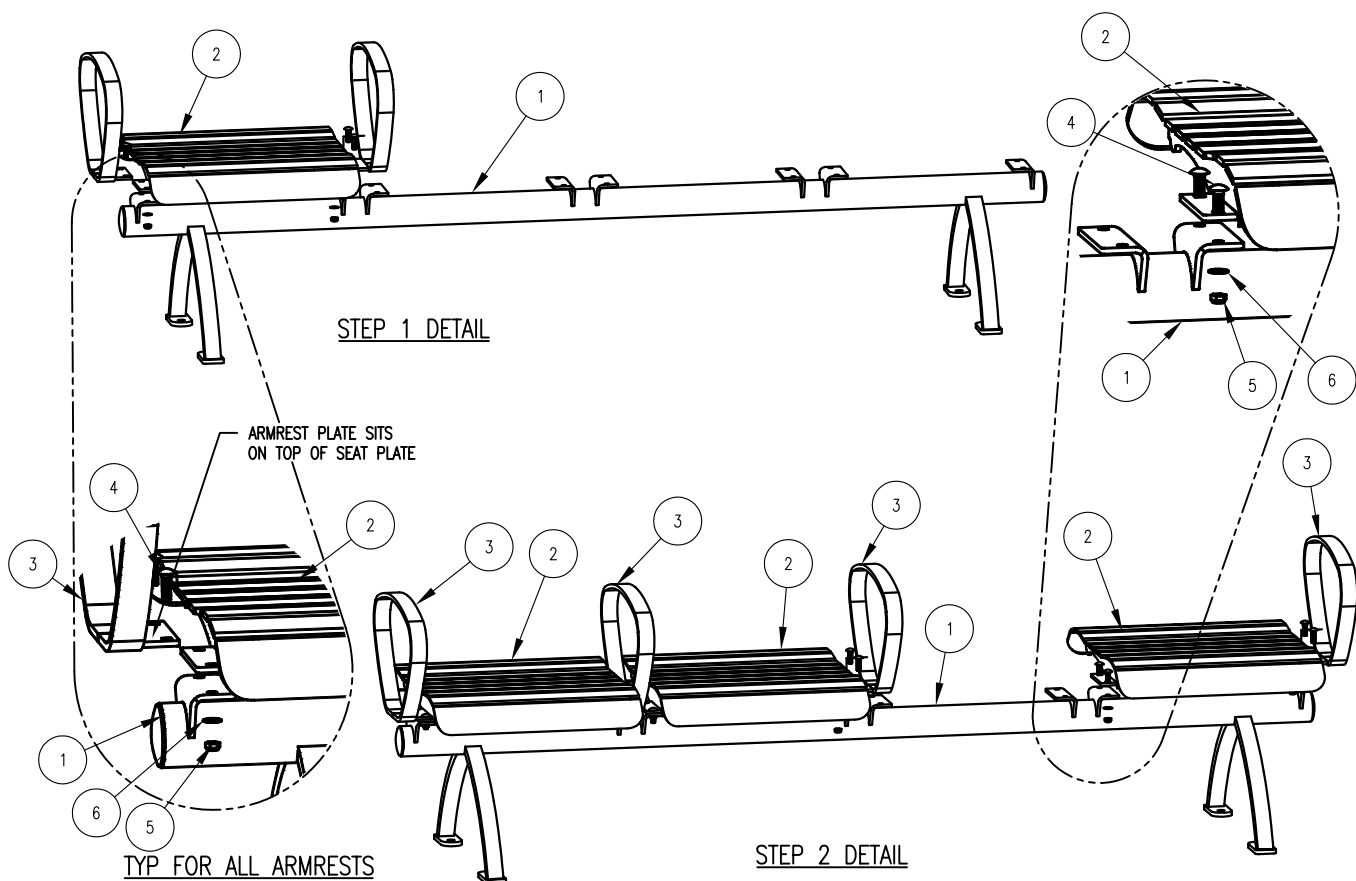

STEP 1:

- USE 1 - PC. SEAT SUPPORT FOR 4 SEATS. FREE STD (1)
 - 1 - PC. STL BKLS SEAT (20") (2)
 - 2 - PCS. STL ARMREST (3)
 - 4 - PCS. 3/8" X 1 1/4" SS. CGE BOLT (5)
 - 4 - PCS. 3/8" SS. THIN NYLON LOCKNUT (6)
 - 4 - PCS. 3/8" SS. FLAT WASHER (7)
- ATTACH STL BKLS SEAT (20") (2), STL ARMREST (3) TO END LOCATION OF SEAT SUPPORT FOR 4 SEATS, FREE STD (1). USING HARDWARE (5, 6 & 7). TIGHTEN TO SNUG FIT.

STEP 2:

- USE 3 - PCS. STL BKLS SEAT (20") (2)
 - 3 - PCS. STL ARMREST (3)
 - 12 - PCS. 3/8" X 1 1/4" SS. CGE BOLT (5)
 - 12 - PCS. 3/8" SS. THIN NYLON LOCKNUT (6)
 - 12 - PCS. 3/8" SS. FLAT WASHER (7)
- ATTACH STL BKLS SEAT (20") (2), STL ARMREST (3) TO STEP 1 ASSEMBLY USING HARDWARE (5, 6 & 7). TIGHTEN TO SNUG FIT.

NOTE:

- 1.) DURING ASSEMBLY PROCEDURE; DO NOT COMPLETELY TIGHTEN HARDWARE.
- 2.) THE ACTUAL PARTS WILL NOT BE NUMBERED: NUMBERS ONLY APPLY TO DRAWING.

STEP 4:

UPON COMPLETION OF BENCH ASSEMBLY SQUARE ALL COMPONENTS THEN TIGHTEN ALL HARDWARE.

STEP 5:

MOUNT AND ANCHOR AS SPECIFIED.

ITEM	QTY	PART NO	DESCRIPTION
1	1	0-424-40-02/S-5	STL SEAT SUPPORT FOR 4 SEATS, FREE STD
2	4	0-427-00-01	STL BKLS SEAT (20")
3	5	0-425-00-02	STL ARMREST
4	16	1-11-019	3/8" X 1 1/4" SS CGE BOLT
5	16	1-20-019	3/8" SS THIN NYLON LOCKNUT
6	16	1-22-024	3/8" SS FLAT WASHER
7	1	K-ANC0860-4	1/2" X 3 3/4" SS ANCHOR KIT (4PC)



DuMor, inc.

P.O. Box 142 Mifflintown, PA 17059-0142

SCALE : NONE
 DATE DRAWN : 8/17/11
 DRAWN BY : JSB
 DATE REV. :
 REV. BY :

TITLE : BENCH ASSEMBLY

REV. A

DRAWING NUMBER 427-45/S-5

SHEET 2 OF 2