

- NOTES:
- 1.) ALL STL. MEMBERS COATED W/ ZINC RICH EPOXY THEN FINISHED W/ POLYESTER POWDER COATING.
 - 2.) 1/2" X 3 3/4" EXPANSION ANCHOR BOLTS PROVIDED.
 - 3.) BENCH IS SHIPPED UNASSEMBLED.

 DuMor, inc. P.O. Box 142 Mifflintown, PA 17059-0142	SCALE :	NONE	TITLE :		BENCH	
	DATE DRAWN :	8/16/11	REV.	DRAWING NUMBER	427-23/S-5	
	DRAWN BY :	JSB	A			
	DATE REV. :					
	REV. BY :					SHEET 1 OF 2

STEP 1 DETAIL

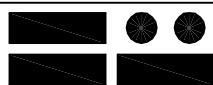
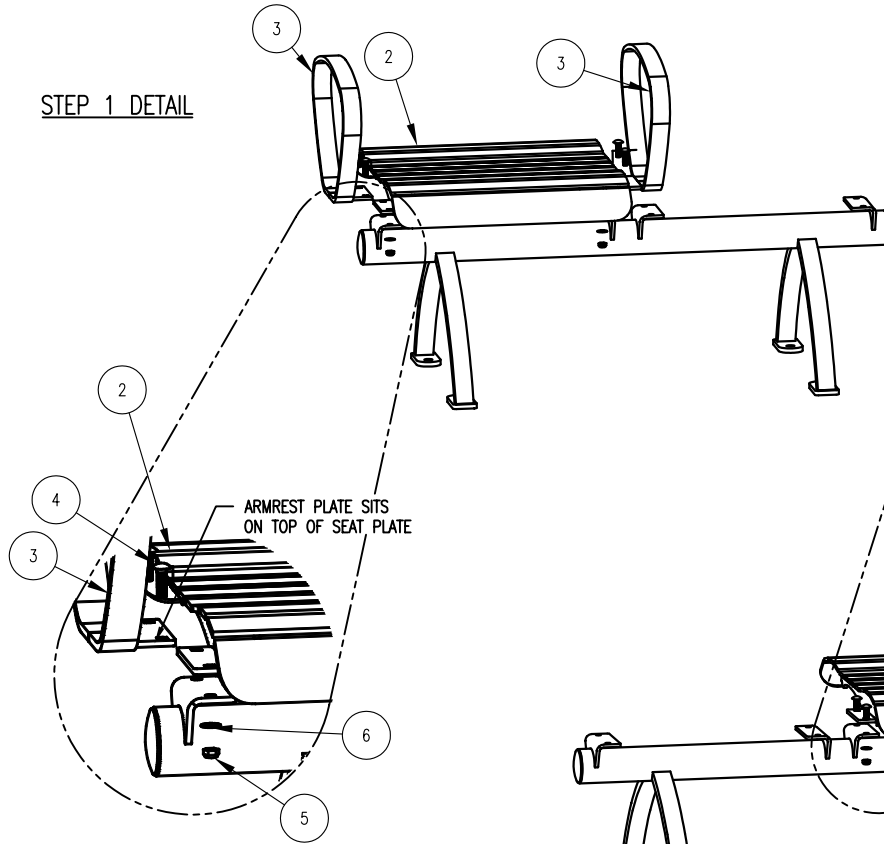

TYP FOR ALL ARMRESTS

STEP 2 DETAIL

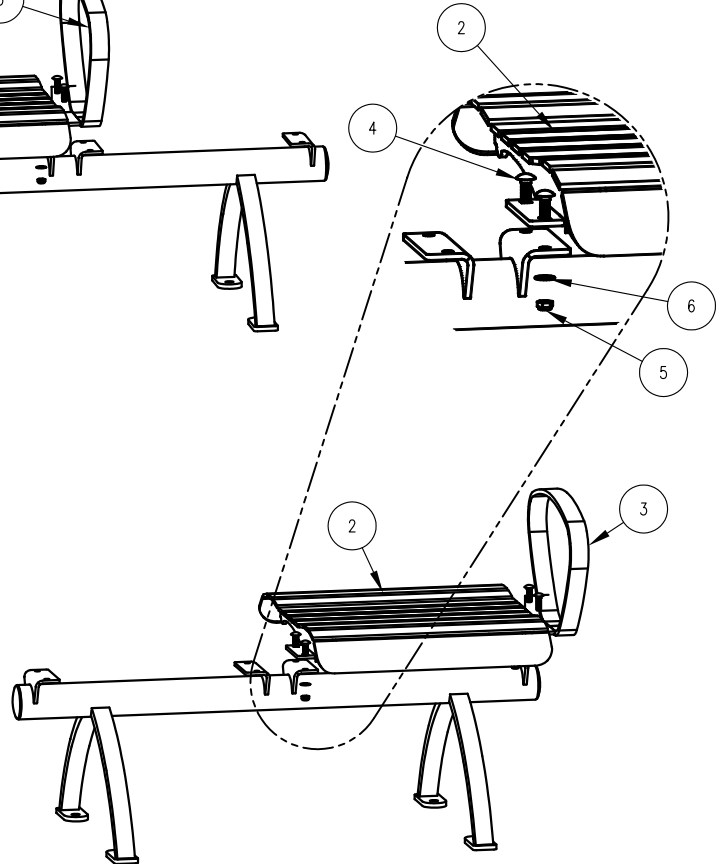

STEP 1:

- USE 1 - PC. SEAT SUPPORT FOR 2 SEATS. FREE STD (1)
- 1 - PC. STL BKLS SEAT (20") (2)
- 2 - PC. STL ARMREST (3)
- 4 - PCS. 3/8" X 1 1/4" SS. CGE BOLT (5)
- 4 - PCS. 3/8" SS. THIN NYLON LOCKNUT (6)
- 4 - PCS. 3/8" SS. FLAT WASHER (7)

ATTACH STL BKLS SEAT (20") (2), STL ARMREST (3) TO SEAT SUPPORT FOR 2 SEATS, FREE STD (1). USING HARDWARE (5, 6 & 7). TIGHTEN TO SNUG FIT.

STEP 2:

- USE 1 - PC. STL BKLS SEAT (20") (2)
- 1 - PC. STL ARMREST (3)
- 4 - PCS. 3/8" X 1 1/4" SS. CGE BOLT (5)
- 4 - PCS. 3/8" SS. THIN NYLON LOCKNUT (6)
- 4 - PCS. 3/8" SS. FLAT WASHER (7)

ATTACH STL BKLS SEAT (20") (2), STL ARMREST (3) TO STEP 1 ASSEMBLY USING HARDWARE (5, 6 & 7). TIGHTEN TO SNUG FIT.

NOTE:

- 1.) DURING ASSEMBLY PROCEDURE;
DO NOT COMPLETELY TIGHTEN HARDWARE.
- 2.) THE ACTUAL PARTS WILL NOT BE NUMBERED:
NUMBERS ONLY APPLY TO DRAWING.

STEP 4:

UPON COMPLETION OF BENCH ASSEMBLY SQUARE ALL COMPONENTS THEN TIGHTEN ALL HARDWARE.

STEP 5:

MOUNT AND ANCHOR AS SPECIFIED.

ITEM	QTY	PART NO	DESCRIPTION
1	1	0-424-20-02/S-5	STL SEAT SUPPORT FOR 2 SEATS, FREE STD
2	2	0-427-00-01	STL BKLS SEAT (20")
3	3	0-425-00-02	STL ARMREST
4	8	1-11-019	3/8" X 1 1/4" SS CGE BOLT
5	8	1-20-019	3/8" SS THIN NYLON LOCKNUT
6	8	1-22-024	3/8" SS FLAT WASHER

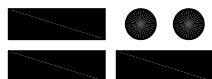

DuMor, inc.

P.O. Box 142 Mifflintown, PA 17059-0142

SCALE : NONE
DATE DRAWN : 8/16/11
DRAWN BY : JSB
DATE REV. :
REV. BY :

TITLE : BENCH ASSEMBLY

REV. A

DRAWING NUMBER 427-23/S-5

SHEET 2 OF 2