

NOTES

- 1.) ALL STL. MEMBERS COATED W/ ZINC RICH EPOXY THEN FINISHED W/ POLYESTER POWDER COATING.
- 2.) 1/2" X 3 3/4" EXPANSION ANCHOR BOLT PROVIDED.

WOOD OPTIONS

- 'C' & BTR. DOUGLAS FIR KD S4S EE
- IPE S4S EE
- OTHER _____

	TABLE	DATE DRAWN : 01/12/16	REV.	DRAWING NUMBER 475-60-1/S-5	SHEET 1 OF 2
		DRAWN BY : ESS	A		
		DATE REV. :			
		REV. BY :			

NOTES:

- 1.) DURING ASSEMBLY PROCEDURE;
DO NOT COMPLETELY TIGHTEN HARDWARE.
- 2.) THE ACTUAL PARTS WILL NOT BE NUMBERED.
NUMBERS ONLY APPLY TO DRAWING.
- 3.) UPON COMPLETION OF ASSEMBLY SQUARE
ALL COMPONENTS THEN TIGHTEN ALL HARDWARE.
- 4.) MOUNT AND ANCHOR AS SPECIFIED.

TOOLS REQ'D

- 3/4" WRENCH
- 1/2" WRENCH
- 9/16" WRENCH
- 1/4" ALLEN WRENCH
- 1/2" MASONRY DRILL BIT
- DRILL

PARTS LIST

ITEM	QTY	PART NO	DESCRIPTION
1	6	0-472-60-03	71" INT'R SLAT, WOOD
2	4	0-472-60-05	2" X 6" X 71" EDGE PROFILE SLAT, WOOD
3	4	0-473-00-01	STL BKLS SUPPORT
4	2	0-473-60-02	6' STL BKLS SEAT FRAME
5	2	0-475-01/S-5	STL TABLE SUPPORT, FREE STD
6	1	0-475-60-1-03	6' STL ACCESSIBLE TABLE FRAME, ONE END
7	1	0-475-60-1-04	2" X 6" X 71" EDGE L PROFILE SLAT FOR WHLCHR, WOOD
8	1	0-475-60-1-05	2" X 6" X 71" EDGE R PROFILE SLAT FOR WHLCHR, WOOD
9	6	0-475-60-1-06	2" X 3" X 71" INT'R SLAT FOR WHLCHR, WOOD
10	16	1-12-133	3/8" X 3/4" SS BTN SKT HD CAP SCR
11	26	1-13-023	5/16" X 1 1/2" SS BTN SKT HD LAG
12	36	1-13-038	5/16" X 2" SS HEX HD LAG SCR
13	62	1-22-017	5/16" SS FLAT WASHER

KITS PROVIDED

ITEM	QTY	PART NO	DESCRIPTION
16	1	K-BL0524-26	5/16" LAG HARDWARE KIT (26PC)
15	4	K-BC0612-4	3/8" CAP HARDWARE KIT (4PC)
14	3	K-ANC0860-4	1/2" X 3 3/4" SS ANCHOR KIT (4PC)
17	3	K-HL0532-12	5/16" LAG HARDWARE KIT (12PC)

①

ATTACH TABLE & SEAT FRAMES TO END SUPPORTS. INSERT HARDWARE THROUGH BOTTOM OF SUPPORTS INTO TAPPED HOLES IN FRAME.

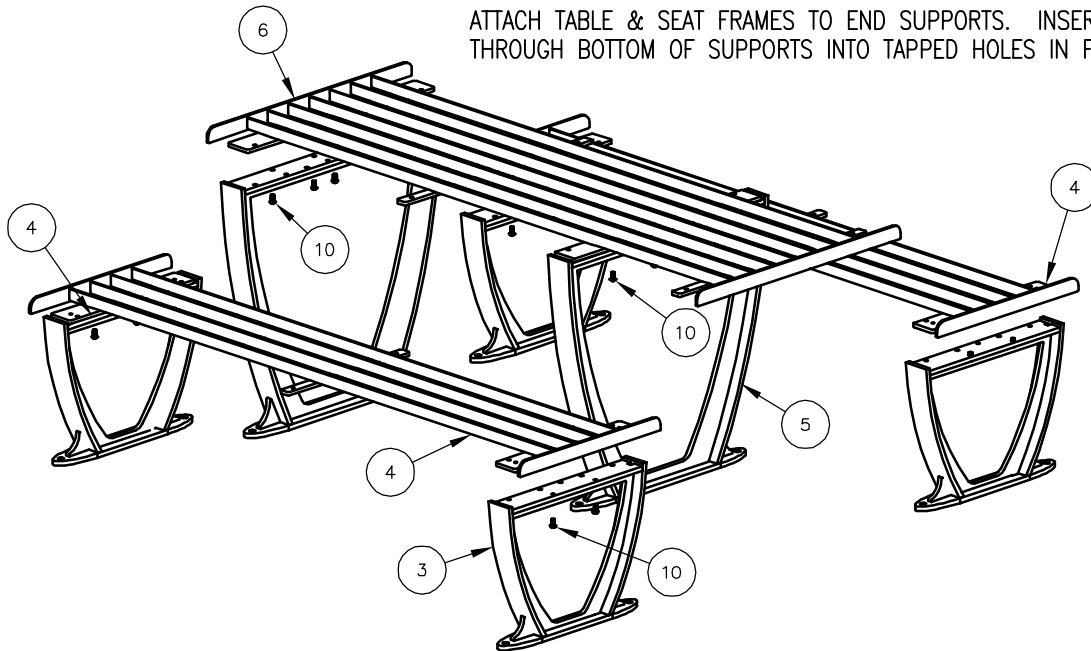

②

ATTACH SLATS TO STEP 1 ASSEMBLY.

