

**NOTES:**

- 1.) ALL STL. MEMBERS COATED W/ ZINC RICH EPOXY THEN FINISHED W/ POLYESTER POWDER COATING.
- 2.) 1/2" X 3 3/4" EXPANSION ANCHOR BOLTS PROVIDED
- 3.) BENCH IS SHIPPED UNASSEMBLED.

**LENGTH OPTIONS**

- 6' BENCH
- 8' BENCH

**DuMor, inc.**  
 P.O. Box 142 Mifflintown, PA 17059-0142

SCALE : NONE  
 DATE DRAWN : 3/22/94  
 DRAWN BY : AH  
 DATE REV. : 5/7/08  
 REV. BY : AH

TITLE : BENCH

REV. G	DRAWING NUMBER 93 SERIES	SHEET 1 OF 2
--------	--------------------------	--------------

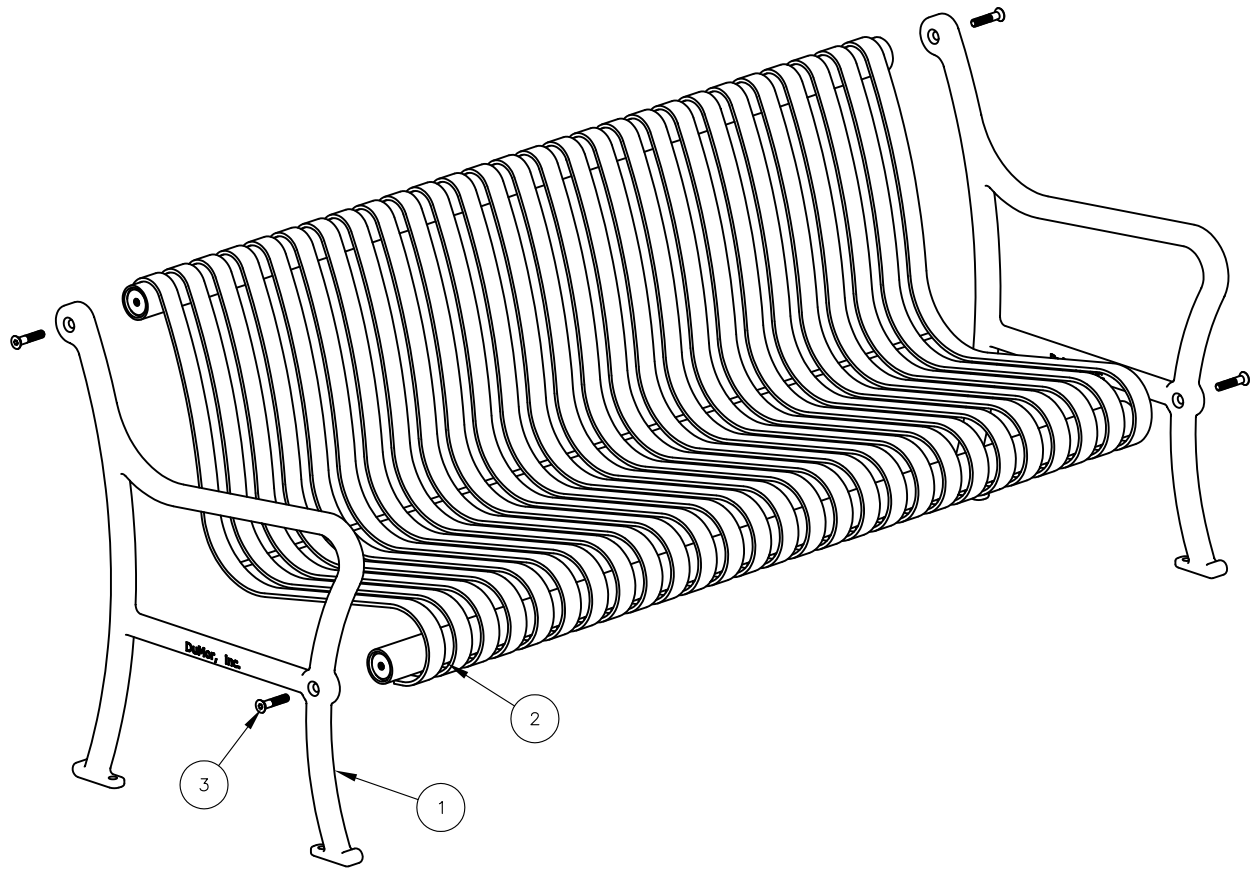

NOTE:

- 1.) DURING ASSEMBLY PROCEDURE;  
DO NOT COMPLETELY TIGHTEN HARDWARE.
- 2.) THE ACTUAL PARTS WILL NOT BE NUMBERED:  
NUMBERS ONLY APPLY TO DRAWING.

STEP 1:

USE 2 - PCS. CAST SUPPORT ( 1 )  
 1 - PC. 6' ALL STL SEAT ASSEMBLY ( 2 )  
 4 - PCS. 1/2" X 2 1/2" FLT. SKT. HD. CAP SCR. ( 3 )  
 ATTACH CAST SUPPORT ( 1 ) TO 6' ALL STL SEAT ASSEMBLY  
 ( 2 ) USING HARDWARE ( 3 ). TIGHTEN TO SNUG FIT.

STEP 2:

UPON COMPLETION OF BENCH ASSEMBLY SQUARE ALL  
 COMPONENTS THEN TIGHTEN ALL HARDWARE.

STEP 3:

MOUNT AND ANCHOR AS SPECIFIED.

ITEM	QTY	PART NO	DESCRIPTION
1	2	0-93-00-02	CAST IRON BENCH SUPPORT
2	1	0-93-60	6' STL SEAT ASSEMBLY
3	4	1-12-065	1/2" X 2 1/2" FLT SKT HD CAP SCR



**DuMor, inc.**  
 P.O. Box 142 Mifflintown, PA 17059-0142

SCALE : NONE  
 DATE DRAWN : 3/22/94  
 DRAWN BY : AWH  
 DATE REV. : 5/7/08  
 REV. BY : AH

TITLE : BENCH ASSEMBLY

REV. G  
 DRAWING NUMBER 93 SERIES

SHEET 2 OF 2