

S-2 SURFACE

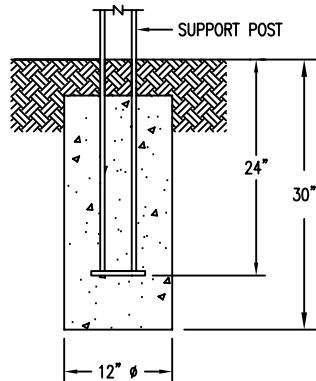

S-1 EMBEDMENT

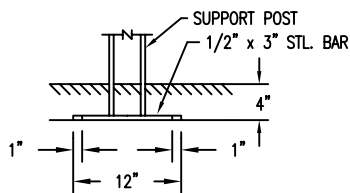

S-4 SUB FLOOR

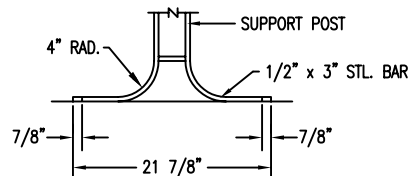

S-3 GULL WING

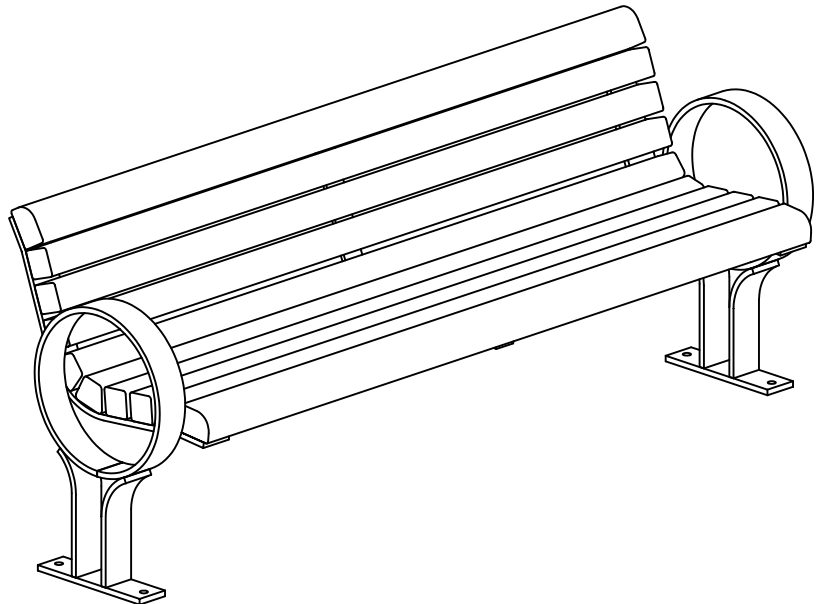
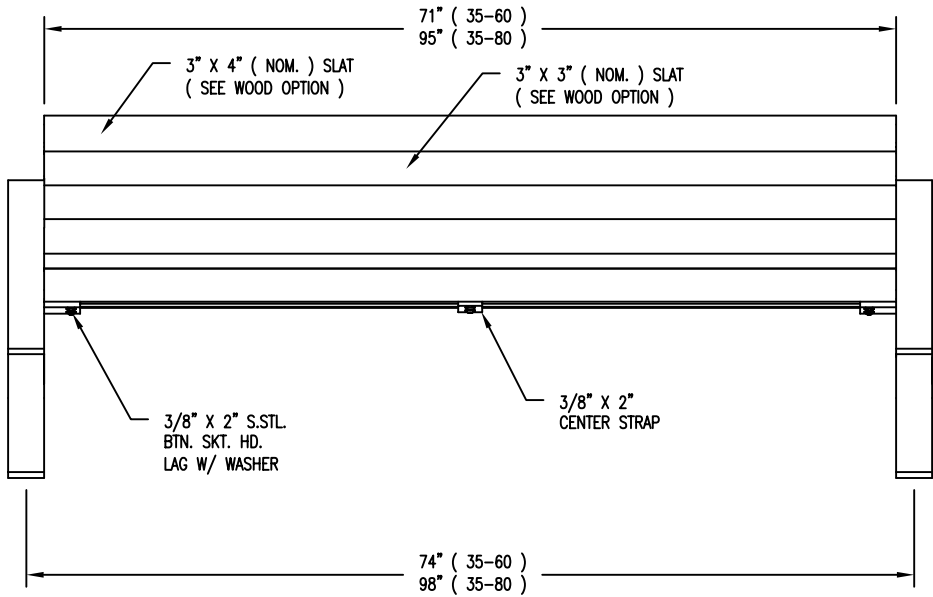

LENGTH OPTIONS

- 6' BENCH
- 8' BENCH

NOTES

- 1.) ALL STL. MEMBERS COATED W/ ZINC RICH EPOXY THEN FINISHED W/ POLYESTER POWDER COATING.
- 2.) ALL WOOD MEMBERS TREATED W/ CLEAR PRESERVATIVE.
- 3.) 1/2" X 3 3/4" EXPANSION ANCHOR BOLTS PROVIDED FOR S-2, S-3 & S-4 OPTIONS.

WOOD OPTIONS

- 'C' & BTR. DOUGLAS FIR KD S4S EE
- IPE S4S EE
- OTHER _____

DuMor, inc.
 P.O. Box 142 Mifflintown, PA 17059-0142

SCALE : NONE
 DATE DRAWN : 3/22/94
 DRAWN BY : AH
 DATE REV. : 10/26/11
 REV. BY : ESS

TITLE : BENCH

REV. E
 DRAWING NUMBER

35 SERIES

SHEET 1 OF 2

SURFACE MOUNT
OPTION SHOWN

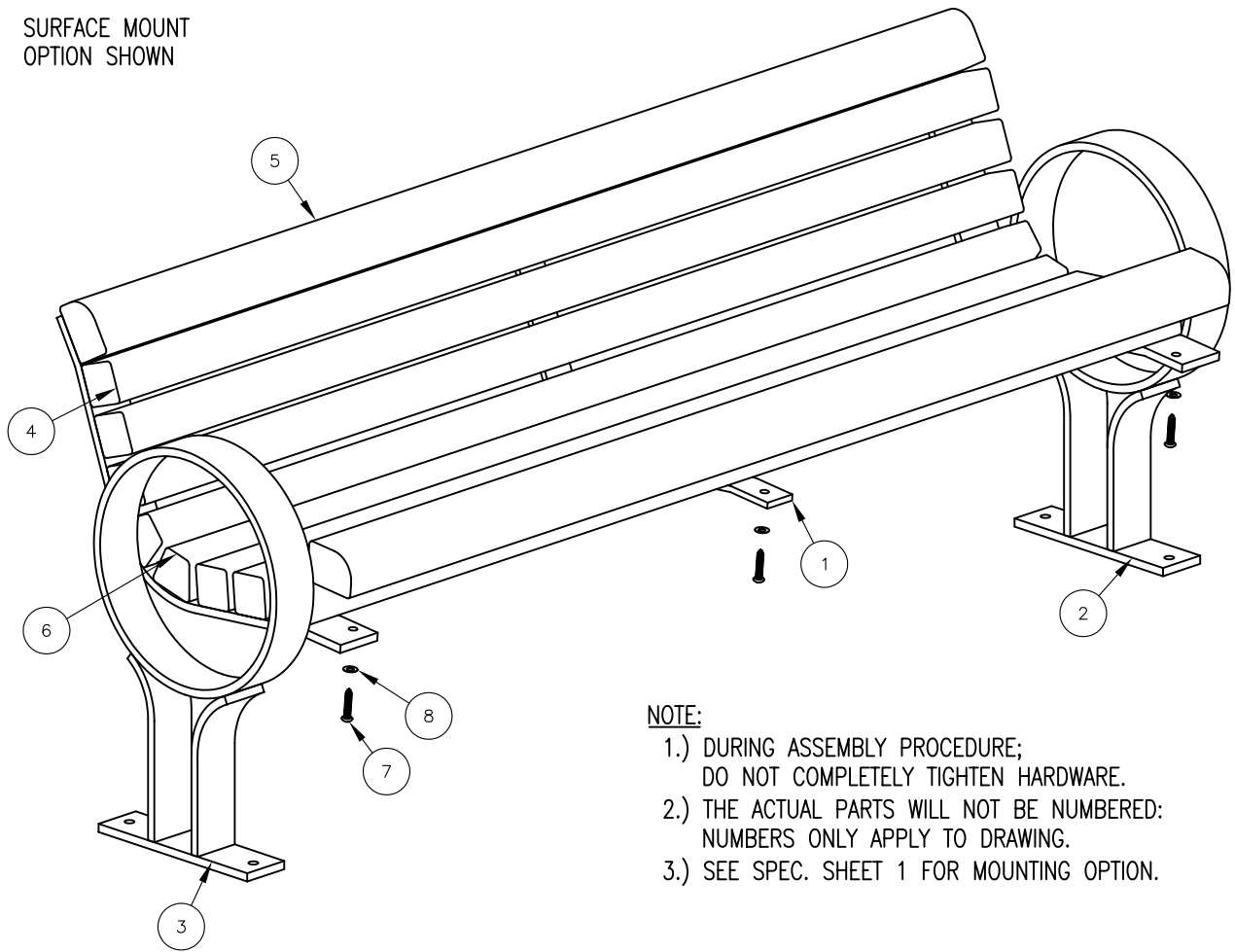

NOTE:

- 1.) DURING ASSEMBLY PROCEDURE;
DO NOT COMPLETELY TIGHTEN HARDWARE.
- 2.) THE ACTUAL PARTS WILL NOT BE NUMBERED:
NUMBERS ONLY APPLY TO DRAWING.
- 3.) SEE SPEC. SHEET 1 FOR MOUNTING OPTION.

STEP 1:

- USE 1 - PC. LEFT BENCH SUPPORT FOR SURFACE MOUNT (2)
- 1 - PC. RIGHT BENCH SUPPORT FOR SURFACE MOUNT (3)
- 6 - PCS. 3" X 3" X 71" WOOD INT'R SLAT (4)
- 2 - PCS. 3" X 4" X 71" WOOD EDGE SLAT (5)
- 2 - PCS. 3" X 4" X 71" WOOD TRAP. SLAT (6)
- 20 - PCS. 3/8" X 2" SS. BTN. SKT. HD. LAG SCR. (7)
- 20 - PCS. 3/8" SS. FLAT WASHER (8)

ATTACH SLAT (4, 5, & 6) TO LEFT BENCH SUPPORT FOR SURFACE MOUNT (2) AND RIGHT BENCH SUPPORT FOR SURFACE MOUNT (3) USING HARDWARE (7 & 8). TIGHTEN TO SNUG FIT.

STEP 3:

UPON COMPLETION OF BENCH ASSEMBLY SQUARE ALL COMPONENTS THEN TIGHTEN ALL HARDWARE.

STEP 4:

ANCHOR ACCORDING TO SUPPORT OPTION USED.

STEP 2:

- USE 1 - PC. CENTER CONTOUR STRAP (1)
- 10 - PCS. 3/8" X 2" SS. BTN. SKT. HD. LAG SCR. (7)
- 10 - PCS. 3/8" SS. FLAT WASHER (8)

ATTACH CENTER CONTOUR STRAP (1) TO STEP 1 ASSEMBLY USING HARDWARE (7 & 8). TIGHTEN TO SNUG FIT.

ITEM	QTY	PART NO	DESCRIPTION
1	1	0-35-00-05	3/8" X 2" CTR CONTOUR STRAP
2	1	0-35-00L-03/S-2	LEFT BENCH SUPPORT FOR SURFACE MOUNT
3	1	0-35-00R-03/S-2	RIGHT BENCH SUPPORT FOR SURFACE MOUNT
4	6	0-35-60-01	3" X 3" X 71" WOOD INT'R SLAT
5	2	0-35-60-02	3" X 4" X 71" WOOD EDGE SLAT
6	2	0-35-60-03	3" X 4" X 71" WOOD TRAP SLAT
7	30	1-13-016	3/8" X 2" SS BTN SKT HD LAG SCR
8	30	1-22-024	3/8" SS FLAT WASHER

DuMor, inc.
P.O. Box 142 Mifflintown, PA 17059-0142

SCALE : NONE
DATE DRAWN : 3/22/94
DRAWN BY : AH
DATE REV. : 12/15/08
REV. BY : ESS

TITLE : BENCH ASSEMBLY

REV. D

DRAWING NUMBER

35 SERIES

SHEET 2 OF 2