

NOTES:

- 1.) ALL STL. MEMBERS COATED W/ ZINC RICH EPOXY THEN FINISHED W/ POLYESTER POWDER COATING.
- 2.) 1/2" X 3 3/4" EXPANSION ANCHOR BOLTS PROVIDED.
- 3.) BENCH IS SHIPPED UNASSEMBLED.

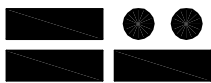

DuMor, inc.
P.O. Box 142 Mifflintown, PA 17059-0142

| | |
|--------------|--------|
| SCALE : | NONE |
| DATE DRAWN : | 8/9/11 |
| DRAWN BY : | JSB |
| DATE REV. : | |
| REV. BY : | |

| | | | |
|---------|----------------|--|--------|
| TITLE : | BENCH | | |
| REV. | DRAWING NUMBER | | SHEET |
| A | 424-34/S-5 | | 1 OF 2 |

STEP 1 DETAIL

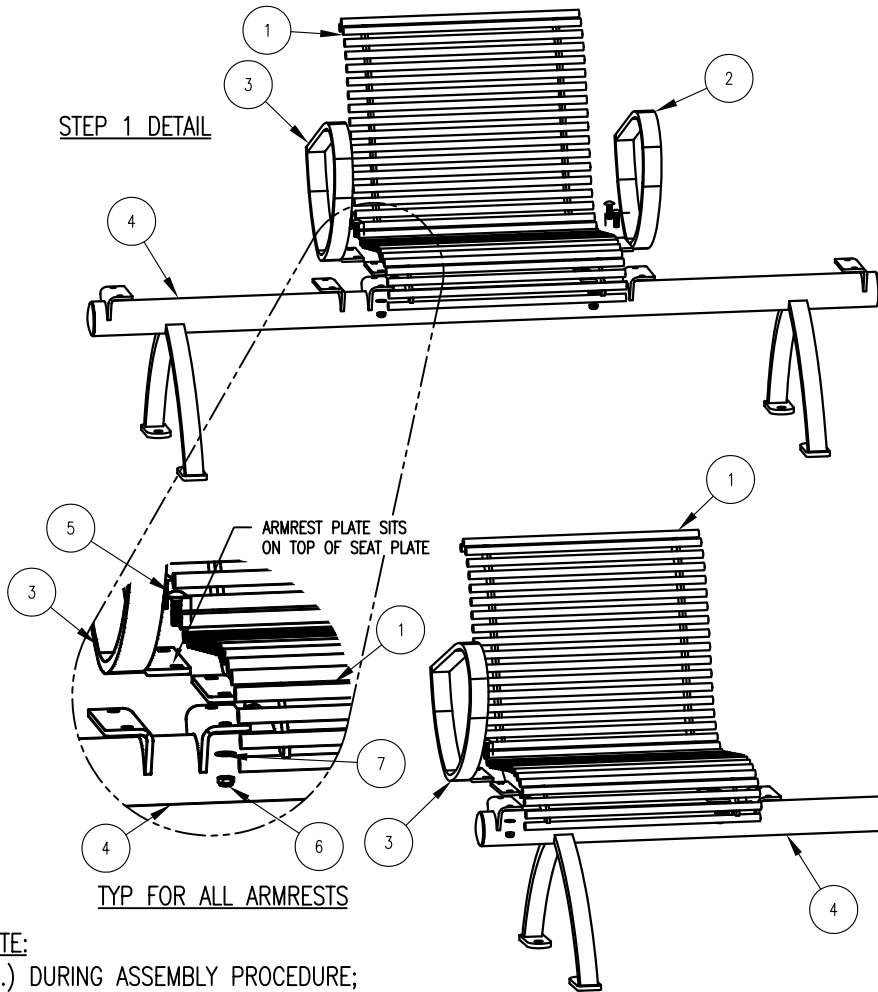

TYP FOR ALL ARMRESTS

STEP 2 & 3 DETAIL

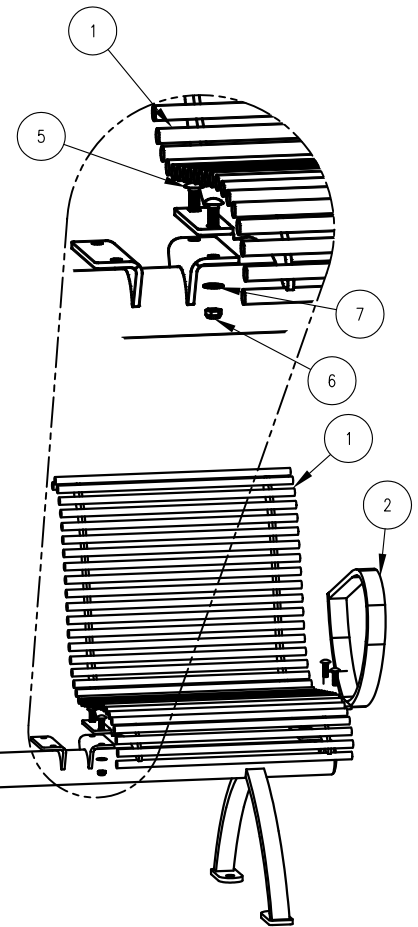

NOTE:

- 1.) DURING ASSEMBLY PROCEDURE;
DO NOT COMPLETELY TIGHTEN HARDWARE.
- 2.) THE ACTUAL PARTS WILL NOT BE NUMBERED;
NUMBERS ONLY APPLY TO DRAWING.

STEP 1:

- USE 1 - PC. SEAT SUPPORT FOR 3 SEATS. FREE STD (4)
 1 - PC. STL SEAT (20") (1)
 1 - PC. LEFT STL ARMREST (2)
 1 - PC. RIGHT STL ARMREST (3)
 4 - PCS. 3/8" X 1 1/4" SS. CGE BOLT (5)
 4 - PCS. 3/8" SS. THIN NYLON LOCKNUT (6)
 4 - PCS. 3/8" SS. FLAT WASHER (7)

ATTACH STL SEAT (20") (1), LEFT STL ARMREST (2) &
 RIGHT STL ARMREST (3) TO CENTER LOCATION OF SEAT
 SUPPORT FOR 3 SEATS, FREE STD (4). USING HARDWARE
 (5, 6 & 7). TIGHTEN TO SNUG FIT.

STEP 2:

- USE 1 - PC. STL SEAT (20") (1)
 1 - PC. LEFT STL ARMREST (2)
 4 - PCS. 3/8" X 1 1/4" SS. CGE BOLT (5)
 4 - PCS. 3/8" SS. THIN NYLON LOCKNUT (6)
 4 - PCS. 3/8" SS. FLAT WASHER (7)
- ATTACH STL SEAT (20") (1), LEFT STL ARMREST (2) TO STEP 1
 ASSEMBLY USING HARDWARE (5, 6 & 7). TIGHTEN TO SNUG FIT.

STEP 3:

- USE 1 - PC. STL SEAT (20") (1)
 1 - PC. RIGHT STL ARMREST (3)
 4 - PCS. 3/8" X 1 1/4" SS. CGE BOLT (5)
 4 - PCS. 3/8" SS. THIN NYLON LOCKNUT (6)
 4 - PCS. 3/8" SS. FLAT WASHER (7)

ATTACH STL SEAT (20") (1), RIGHT STL ARMREST (3) TO STEP 2
 ASSEMBLY USING HARDWARE (5, 6 & 7). TIGHTEN TO SNUG FIT.

STEP 4:

UPON COMPLETION OF BENCH ASSEMBLY SQUARE ALL
 COMPONENTS THEN TIGHTEN ALL HARDWARE.

STEP 5:

MOUNT AND ANCHOR AS SPECIFIED.

| ITEM | QTY | PART NO | DESCRIPTION |
|------|-----|-----------------|--|
| 1 | 3 | 0-424-00-01 | STL SEAT (20") |
| 2 | 2 | 0-424-00L-03 | LEFT STL ARMREST |
| 3 | 2 | 0-424-00R-03 | RIGHT STL ARMREST |
| 4 | 1 | 0-424-30-02/S-5 | STL SEAT SUPPORT FOR 3 SEATS, FREE STD |
| 5 | 12 | 1-11-019 | 3/8" X 1 1/4" SS CGE BOLT |
| 6 | 12 | 1-20-019 | 3/8" SS THIN NYLON LOCKNUT |
| 7 | 12 | 1-22-024 | 3/8" SS FLAT WASHER |

DuMor, inc.

P.O. Box 142 Mifflintown, PA 17059-0142

SCALE : NONE
 DATE DRAWN : 8/9/11
 DRAWN BY : JSB
 DATE REV. :
 REV. BY :

TITLE : BENCH ASSEMBLY

REV. A
 DRAWING NUMBER 424-34/S-5

SHEET 2 OF 2