

NOTES

- 1.) ALL STL. MEMBERS COATED W/ ZINC RICH EPOXY THEN FINISHED W/ POLYESTER POWDER COATING.
- 2.) 1/2" X 3 3/4" EXPANSION ANCHOR BOLTS PROVIDED.



TABLE

DATE DRAWN : 01/10/14
 DRAWN BY : RDH
 DATE REV. : 11/11/15
 REV. BY : JSB

REV.
B

DRAWING
NUMBER

463-20VS

SHEET
1 OF 2

PARTS LIST

ITEM	QTY	PART NO	DESCRIPTION
1	1	0-126-05	TABLE TOP WITH BOLT TABS
2	2	0-462-00-01	STL TABLE SUPPORT FRAME, 1 SEAT
3	1	0-462-00-02	3/8" THK STL BOLT PLATE
4	8	0-462-00-04	15 3/4" ALUM EXTRUSION
5	2	0-462-00-07	STL TABLE SUPPORT FRAME, NO SEAT
6	4	0-462-VS-01	10 GA 12 3/8" X 15 3/4" STL PLATE
7	2	0-463-00-03L	LEFT STL SEAT FRAME
8	2	0-463-00-03R	RIGHT STL SEAT FRAME
9	4	1-11-003	3/8" X 1 1/2" SS CGE BOLT
10	12	1-11-042	1/2" X 1 1/2" SS CGE BOLT
11	16	1-12-053	5/16" X 1 1/2" SS BTN SKT HD CAP SCR
12	4	1-20-007	3/8" SS NYLON LOCKNUT
13	12	1-20-015	1/2" SS NYLON LOCKNUT
14	12	1-22-015	1/2" SS FLAT WASHER
15	4	1-22-024	3/8" SS FLAT WASHER

NOTES:

- 1.) DURING ASSEMBLY PROCEDURE; DO NOT COMPLETELY TIGHTEN HARDWARE.
- 2.) THE ACTUAL PARTS WILL NOT BE NUMBERED. NUMBERS ONLY APPLY TO DRAWING.
- 3.) UPON COMPLETION OF ASSEMBLY SQUARE ALL COMPONENTS THEN TIGHTEN ALL HARDWARE.
- 4.) MOUNT AND ANCHOR AS SPECIFIED.

TOOLS REQ'D

- 3/4" WRENCH
- 9/16" WRENCH
- 3/16" ALLEN WRENCH
- 1/2" MASONRY DRILL BIT
- DRILL

KITS PROVIDED

ITEM	QTY	PART NO	DESCRIPTION
16	1	K-ANC0860-4	1/2" X 3 3/4" SS ANCHOR KIT (4PC)
17	2	K-BC0524-8	5/16" CAP HARDWARE KIT (8PC)
18	1	K-CG0624-4L	3/8" CGE BOLT HARDWARE KIT (4PC)
19	3	K-CG0824-4L	1/2" CGE BOLT HARDWARE KIT (4)

1 ATTACH 4 SUPPORTS TOGETHER.

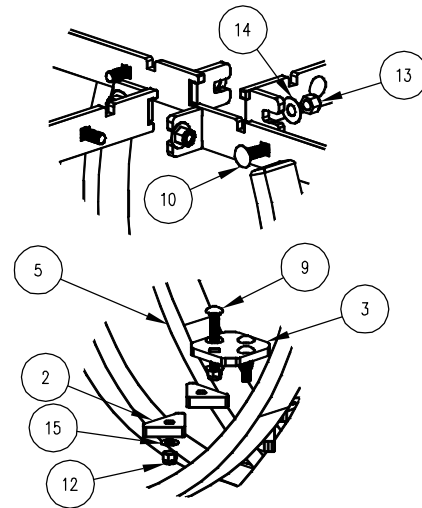
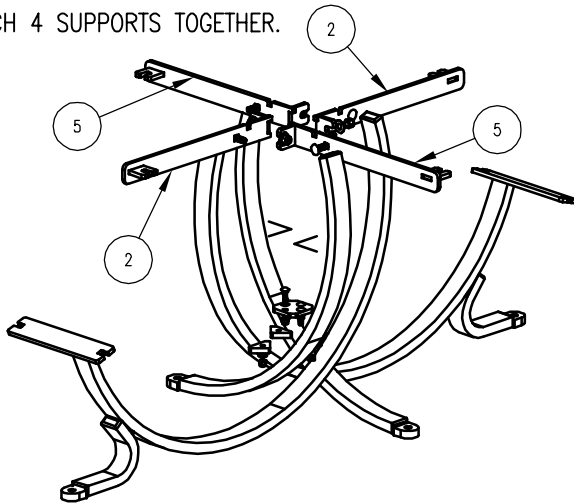

2 ATTACH TABLE TOP TO STEP 1.

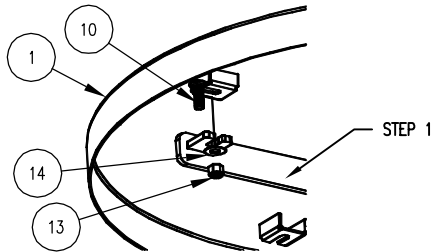

3 ATTACH ALUM. EXTRUSION TO LEFT & RIGHT SEAT FRAMES, ENSURE PINS ARE IN "L" SLOTS. ATTACH TO STEP 1.

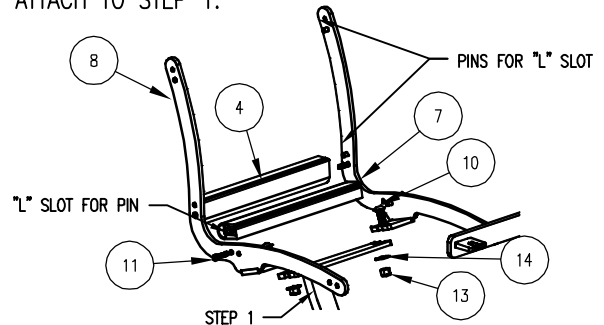

4 INSERT SEAT/BACK INTO STEP 3, USING SLOT ON ALUM. EXTRUSION.

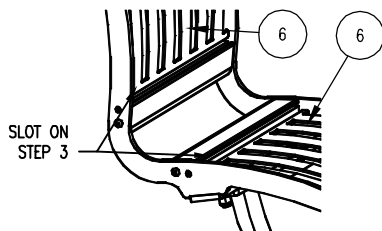

5 ATTACH REMAINING ALUM. EXTRUSIONS TO SEAT FRAMES, AS IN STEP 3.

