

WOOD OPTIONS

- 'C' & BTR. DOUGLAS FIR KD S4S EE
- IPE S4S EE
- OTHER _____

NOTES

- 1.) ALL STL. MEMBERS COATED W/ ZINC RICH EPOXY THEN FINISHED W/ POLYESTER POWDER COATING.
- 2.) 1/2" X 3 3/4" EXPANSION ANCHOR BOLTS PROVIDED.

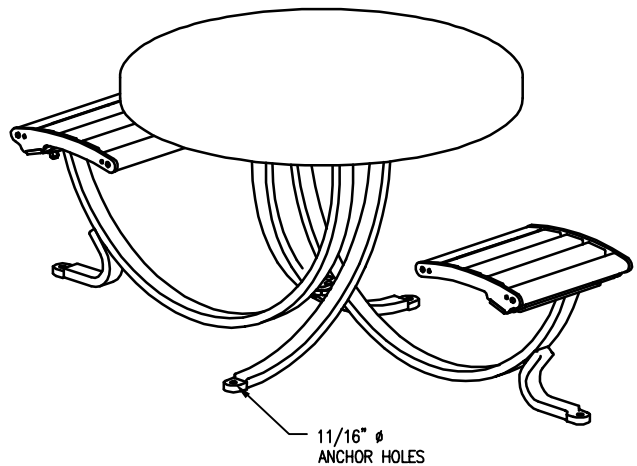

TABLE

DATE DRAWN : 11/6/15
 DRAWN BY : JSB
 DATE REV. : 00/00/00
 REV. BY : XXX

REV.
A

DRAWING NUMBER

462-20

SHEET
1 OF 2

PARTS LIST

ITEM	QTY	PART NO	DESCRIPTION
1	1	0-126-05	TABLE TOP WITH BOLT TABS
2	4	0-460-00-02	CONTOUR STRAP
3	2	0-462-00-01	STL TABLE SUPPORT FRAME, 1 SEAT
4	1	0-462-00-02	3/8" THK STL BOLT PLATE
5	4	0-462-00-04	15 3/4" ALUM EXTRUSION
6	6	0-462-00-05	2" X 3" X 15" SLAT, WOOD
7	2	0-462-00-07	STL TABLE SUPPORT FRAME, NO SEAT
8	2	0-462-00L-03	LEFT STL BKLS SEAT FRAME
9	2	0-462-00R-03	RIGHT STL BKLS SEAT FRAME
10	4	1-11-003	3/8" X 1 1/2" SS CGE BOLT
11	12	1-11-042	1/2" X 1 1/2" SS CGE BOLT
12	8	1-12-053	5/16" X 1 1/2" SS BTN SKT HD CAP SCR
13	12	1-13-023	5/16" X 1 1/2" SS BTN SKT HD LAG
14	4	1-20-007	3/8" SS NYLON LOCKNUT
15	12	1-20-015	1/2" SS NYLON LOCKNUT
16	12	1-22-015	1/2" SS FLAT WASHER
17	12	1-22-017	5/16" SS FLAT WASHER
18	4	1-22-024	3/8" SS FLAT WASHER

NOTES:

- 1.) DURING ASSEMBLY PROCEDURE; DO NOT COMPLETELY TIGHTEN HARDWARE.
- 2.) THE ACTUAL PARTS WILL NOT BE NUMBERED. NUMBERS ONLY APPLY TO DRAWING.
- 3.) UPON COMPLETION OF ASSEMBLY SQUARE ALL COMPONENTS THEN TIGHTEN ALL HARDWARE.
- 4.) MOUNT AND ANCHOR AS SPECIFIED.

TOOLS REQ'D

- 3/4" WRENCH
- 9/16" WRENCH
- 1/4" ALLEN WRENCH
- 3/16" ALLEN WRENCH
- 1/2" MASONRY DRILL BIT
- DRILL

KITS PROVIDED

ITEM	QTY	PART NO	DESCRIPTION
19	1	K-ANC0860-4	1/2" X 3 3/4" SS ANCHOR KIT (4PC)
20	2	K-BC0524-4	5/16" CAP HARDWARE KIT (4PC)
21	1	K-BL0524-12	5/16" LAG HARDWARE KIT (12PC)
22	1	K-CG0624-4L	3/8" CGE BOLT HARDWARE KIT (4PC)
23	3	K-CG0824-4L	1/2" CGE BOLT HARDWARE KIT (4)

① ATTACH 4 SUPPORTS TOGETHER.

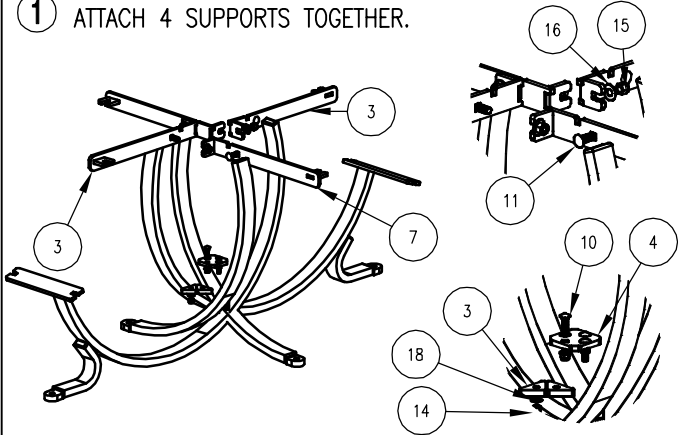

② ATTACH TABLE TOP TO STEP 1.

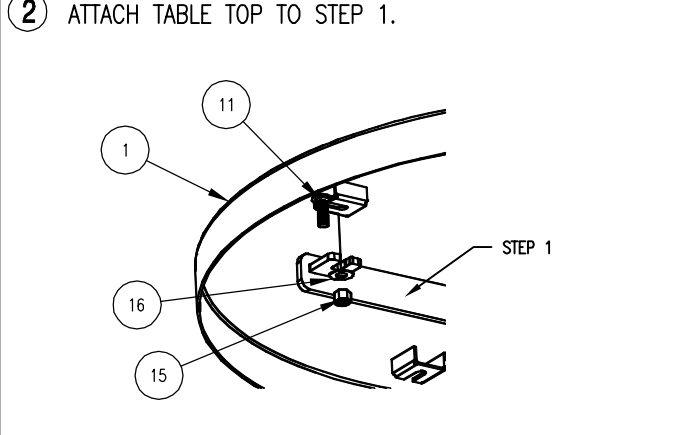

③ ATTACH SLATS TO CONTOUR STRAPS.

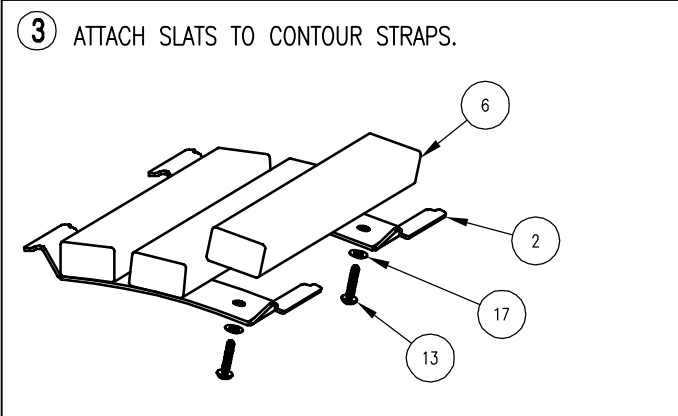

④ ATTACH ALUM. EXTRUSION TO LEFT & RIGHT SEAT FRAMES, ENSURE PINS ARE IN "L" SLOTS. ATTACH TO STEP 1.

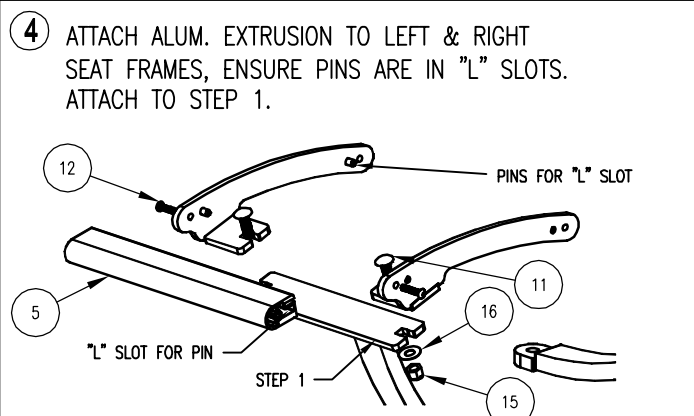

⑤ INSERT STEP 3 INTO STEP 4, USING SLOT ON ALUM. EXTRUSION.

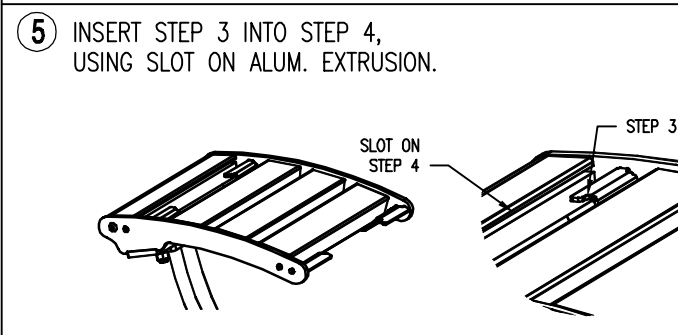

⑥ ATTACH REMAINING ALUM. EXTRUSIONS TO SEAT FRAMES, AS IN STEP 4.

