

**NOTES**

- 1.) ALL STL. MEMBERS COATED W/ ZINC RICH EPOXY THEN FINISHED W/ POLYESTER POWDER COATING.
- 2.) 1/2" X 3 3/4" EXPANSION ANCHOR BOLTS PROVIDED.

**WOOD OPTIONS**

- 'C' & BTR. DOUGLAS FIR KD S4S EE
- IPE S4S EE
- OTHER \_\_\_\_\_



BENCH

DATE DRAWN : 7/10/14  
 DRAWN BY : JSB  
 DATE REV. : 11/18/15  
 REV. BY : JSB

REV.  
B

DRAWING NUMBER

480-40

SHEET  
1 OF 2

**NOTES:**

- 1.) DURING ASSEMBLY PROCEDURE;  
DO NOT COMPLETELY TIGHTEN HARDWARE.
- 2.) THE ACTUAL PARTS WILL NOT BE NUMBERED.  
NUMBERS ONLY APPLY TO DRAWING.
- 3.) UPON COMPLETION OF ASSEMBLY SQUARE  
ALL COMPONENTS THEN TIGHTEN ALL HARDWARE.
- 4.) MOUNT AND ANCHOR AS SPECIFIED.

**TOOLS REQ'D**

- 3/4" WRENCH
- 3/16" ALLEN WRENCH
- 1/4" ALLEN WRENCH
- 1/2" MASONRY DRILL BIT  
DRILL

ITEM	QTY	PART NO	PARTS LIST	DESCRIPTION
1	6	0-460-00-02		CONTOUR STRAP
2	4	0-460-40-03		47 3/4" ALUM EXTRUSION
3	1	0-480-00L-01		LEFT STL BENCH SUPT
4	1	0-480-00R-01		RIGHT STL SEAT SUPPORT
5	6	0-57-40-01		2" X 3" X 47" WOOD CENTER SLAT
6	8	1-12-116		5/16" X 1" SS BTN SKT HD CAP SCR
7	18	1-13-023		5/16" X 1 1/2" SS BTN SKT HD LAG
8	18	1-22-017		5/16" SS FLAT WASHER

**KITS PROVIDED**

ITEM	QTY	PART NO	DESCRIPTION
9	1	K-ANCO860-4	1/2" X 3 3/4" SS ANCHOR KIT (4PC)
10	1	K-BC0524-8	5/16" CAP HARDWARE KIT (8PC)
11	1	K-BL0524-18	5/16" LAG HARDWARE KIT (18PC)

**1** ATTACH SEAT SLATS TO CONTOUR STRAPS

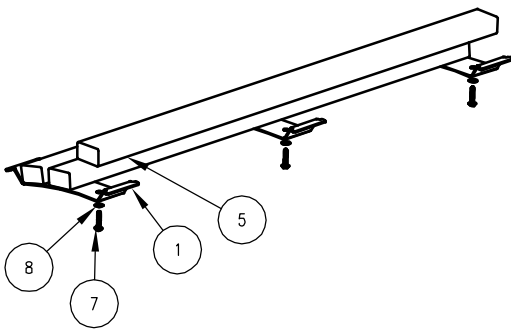

**2** ATTACH ALUM EXTRUSION TO SUPPORTS. TIGHTEN HARDWARE ON ONE SIDE ONLY AND LOOSELY ATTACH THE OTHER SIDE ( SUPPORT )

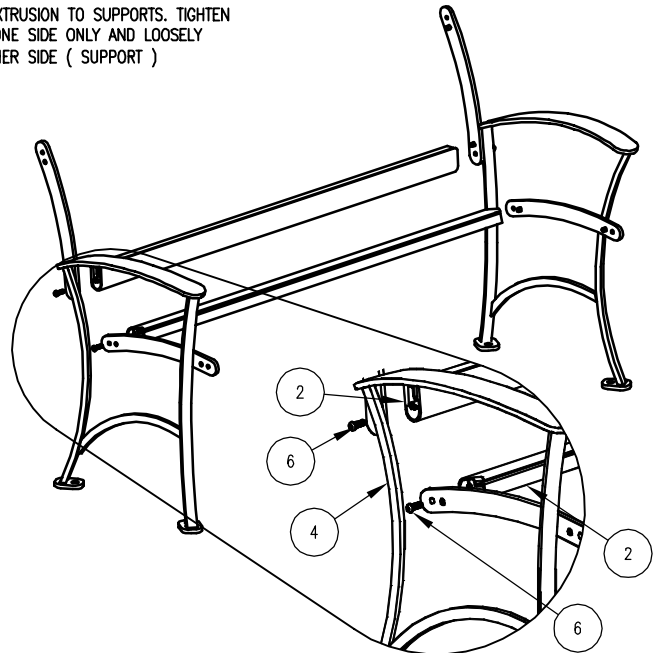

**3** ATTACH STEP1 & ALUM EXTRUSION TO STEP 2. YOU WILL HAVE TO SPREAD THE SUPPORTS APART FOR THE ALUM EXTRUSION TO SLIDE OVER THE PIN ON THE SUPPORTS.

