

NOTES

- 1.) ALL STL. MEMBERS COATED W/ ZINC RICH EPOXY THEN FINISHED W/ POLYESTER POWDER COATING.
- 2.) 1/2" X 3 3/4" EXPANSION ANCHOR BOLTS PROVIDED.

SLAT OPTIONS

- "CEDAR" RECYCLED PLASTIC
- "GREY" RECYCLED PLASTIC
- "REDWOOD" RECYCLED PLASTIC
- "WALNUT" RECYCLED PLASTIC
- OTHER \_\_\_\_\_

PARTS LIST

ITEM	QTY	PART NO	DESCRIPTION
1	6	0-143-60PL-01	2" X 3" X 71" INT'R SLAT, PLASTIC
2	8	0-460-00-02	CONTOUR STRAP
3	1	0-460-00L-01	LEFT BENCH SUPPORT
4	1	0-460-00R-01	RIGHT BENCH SUPPORT
5	4	0-460-60-03	71 3/4" ALUM EXTRUSION
6	8	1-12-053	5/16" X 1 1/2" SS BTN SKT HD CAP SCR
7	24	1-13-023	5/16" X 1 1/2" SS BTN SKT HD LAG
8	24	1-22-017	5/16" SS FLAT WASHER

KITS PROVIDED

ITEM	QTY	PART NO	DESCRIPTION
9	1	K-ANCO860-4	1/2" X 3 3/4" SS ANCHOR KIT (4PC)
10	1	K-BC0524-8	5/16" CAP HARDWARE KIT (8PC)
11	1	K-BL0524-24	5/16" LAG HARDWARE KIT (24PC)

NOTE:

- 1.) DURING ASSEMBLY PROCEDURE; DO NOT COMPLETELY TIGHTEN HARDWARE.
- 2.) THE ACTUAL PARTS WILL NOT BE NUMBERED. NUMBERS ONLY APPLY TO DRAWING.
- 3.) UPON COMPLETION OF ASSEMBLY SQUARE ALL COMPONENTS THEN TIGHTEN ALL HARDWARE.
- 4.) MOUNT AND ANCHOR AS SPECIFIED.

TOOLS REQ'D

- 3/4" WRENCH  
 1/4" ALLEN WRENCH  
 3/16" ALLEN WRENCH  
 1/2" MASONRY DRILL BIT  
 DRILL

1 ATTACH SLATS TO CONTOUR STRAPS.

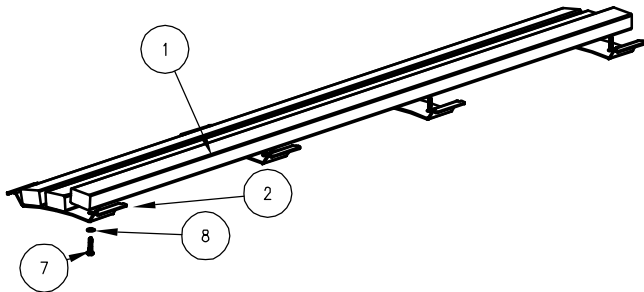

2 ATTACH 2 ALUM. EXTRUSIONS AS SHOWN, TO LEFT & RIGHT BENCH SUPPORTS, ENSURE PINS ARE IN "L" SLOTS.

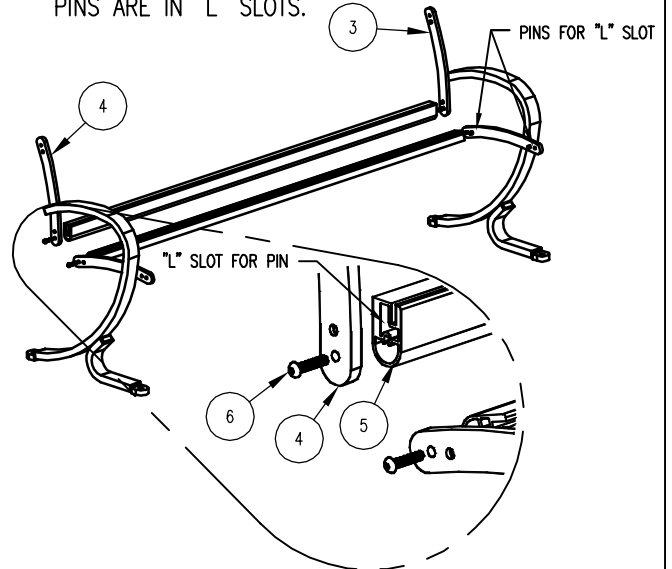

3 INSERT STEP 1 INTO STEP 2, USING SLOTS ON ALUM. EXTRUSION. \*NOTE: RIGHT BENCH SUPPORT NOT SHOWN FOR CLARITY.\*

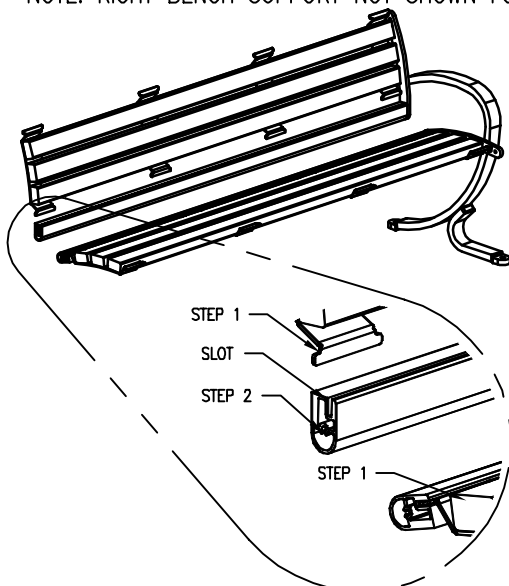

4 ATTACH 2 REMAINING ALUM. EXTRUSIONS TO SUPPORTS, AS IN STEP 2.

