

**NOTES:**

- 1.) ALL STL. MEMBERS COATED W/ ZINC RICH EPOXY THEN FINISHED W/ POLYESTER POWDER COATING.
- 2.) BENCH IS SHIPPED UNASSEMBLED.
- 3.) 1/2" X 3 3/4" EXPANSION ANCHOR BOLTS PROVIDED.



BENCH

DATE DRAWN : 8/26/14  
 DRAWN BY : JSB  
 DATE REV. : 00/00/00  
 REV. BY : XXX

REV.  
A

DRAWING  
NUMBER

R92-120-6

SHEET  
1 OF 2

**NOTES:**

- 1.) DURING ASSEMBLY PROCEDURE; DO NOT COMPLETELY TIGHTEN HARDWARE.
- 2.) THE ACTUAL PARTS WILL NOT BE NUMBERED. NUMBERS ONLY APPLY TO DRAWING.
- 3.) UPON COMPLETION OF ASSEMBLY SQUARE ALL COMPONENTS THEN TIGHTEN ALL HARDWARE.
- 4.) MOUNT AND ANCHOR AS SPECIFIED.

**TOOLS REQ'D**

- 3/4" WRENCH
- 5/16" ALLEN WRENCH
- 1/2" MASONRY DRILL BIT
- DRILL
- RATCHET STRAP (PROVIDED)

**PARTS LIST**

ITEM	QTY	PART NO	DESCRIPTION
1	1	0-R92-120-6-1	120" RAD 6' STL BKLS SEAT
2	2	0-91-00-02	BKLESS CAST IRON BNCH SUPT
3	1	0-R92-120-6-2	120" RAD 6' PIPE BRACE
4	6	1-12-065	1/2" X 2 1/2" FLT SKT HD CAP SCR

**KITS PROVIDED**

ITEM	QTY	PART NO	DESCRIPTION
5	1	K-ANC0860-4	1/2" X 3 3/4" SS ANCHOR KIT (4PC)
6	1	K-FC0840-6	1/2" CAP HARDWARE KIT (6PC)

**1** ATTACH CAST IRON BENCH SUPPORT TO STL. SEAT

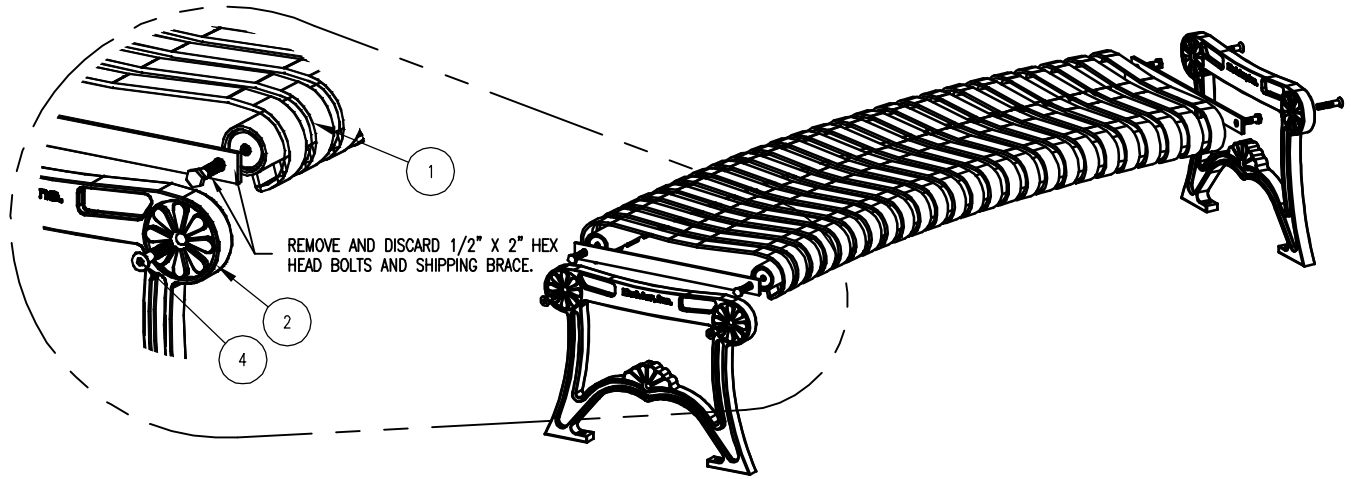

**1A**



PLACE SEAT ASSEMBLY ON WORK SURFACE ALLOWING ACCESS TO ENDS. PLACE RATCHET STRAP AROUND SEAT ASSEMBLY AS SHOWN ABOVE.

**1B**



TIGHTEN STRAP UNTIL SHIPPING BRACKET BECOMES LOOSE. THEN REMOVE AND DISCARD BOLTS & SHIPPING BRACKET.

**1C**



ATTACH CAST SUPPORT TO SEAT ASSEMBLY. IF HOLES IN CASTING DO NOT ALIGN WITH THE SEAT ASSEMBLY, ADJUST BY USING THE RATCHET STRAP.

**1D**



TIGHTEN HARDWARE THEN REMOVE RATCHET STRAP AND REPEAT THIS PROCEDURE ON THE OTHER END OF BENCH.

**2** ATTACH PIPE BRACE TO STEP 1.

