

NOTES

- 1.) ALL STL. MEMBERS COATED W/ ZINC RICH EPOXY THEN FINISHED W/ POLYESTER POWDER COATING.
- 2.) $\frac{1}{2}$ " x $3 \frac{3}{4}$ " EXPANSION ANCHOR BOLTS PROVIDED.

NOTES:

- 1.) DURING ASSEMBLY PROCEDURE;
DO NOT COMPLETELY TIGHTEN HARDWARE.
- 2.) THE ACTUAL PARTS WILL NOT BE NUMBERED.
NUMBERS ONLY APPLY TO DRAWING.
- 3.) UPON COMPLETION OF ASSEMBLY SQUARE
ALL COMPONENTS THEN TIGHTEN ALL HARDWARE.
- 4.) MOUNT AND ANCHOR AS SPECIFIED.

TOOLS REQ'D

- 3/4" WRENCH
- 9/16" WRENCH
- 1/2" MASONRY DRILL BIT
- DRILL

PARTS LIST

ITEM	QTY	PART NO	DESCRIPTION
1	2	0-470-00-01	STL SUPPORT
3	2	0-470-00-09	BACKREST BOLT PLATE
4	1	0-470-60HS-02	6 STL BACKREST, HORIZONTAL STRAPS
5	1	0-470-60HS-03	6 STL SEAT, HORIZONTAL STRAPS
6	8	1-11-003	3/8" X 1 1/2" SS CGE BOLT
7	4	1-11-028	3/8" X 1" SS CGE BOLT
9	8	1-20-007	3/8" SS NYLON LOCKNUT
10	4	1-20-019	3/8" SS THIN NYLON LOCKNUT
11	12	1-22-024	3/8" SS FLAT WASHER

KITS PROVIDED

ITEM	QTY	PART NO	DESCRIPTION
12	1	K-ANCO860-4	1/2" X 3 3/4" SS ANCHOR KIT (4PC)
13	1	K-CG0616-4TL	3/8" CGE BOLT HARDWARE KIT (4PC)
14	2	K-CG0624-4L	3/8" CGE BOLT HARDWARE KIT (4PC)

① ATTACH SEAT TO SUPPORTS.

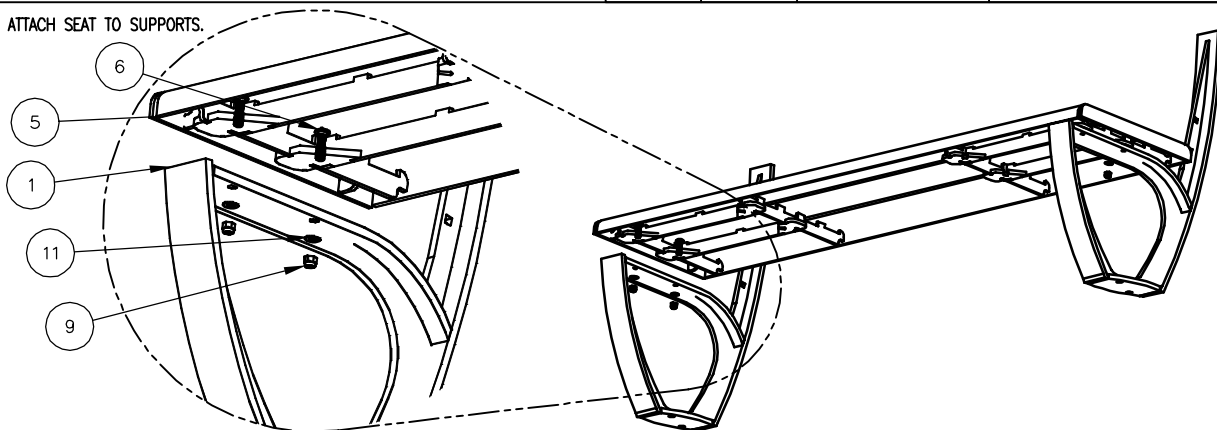

② ATTACH BACKREST BOLT PLATE TO STEP 1.

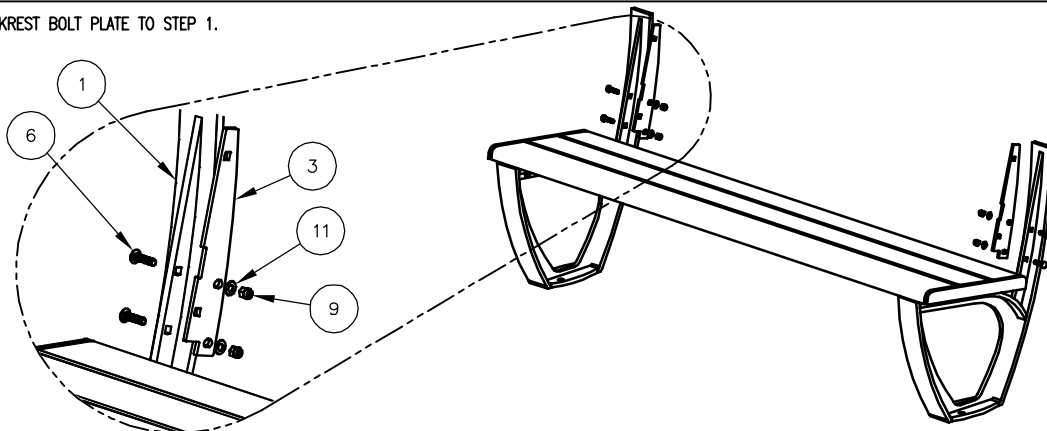

③ ATTACH BACKREST BOLT PLATE TO STEP 2.

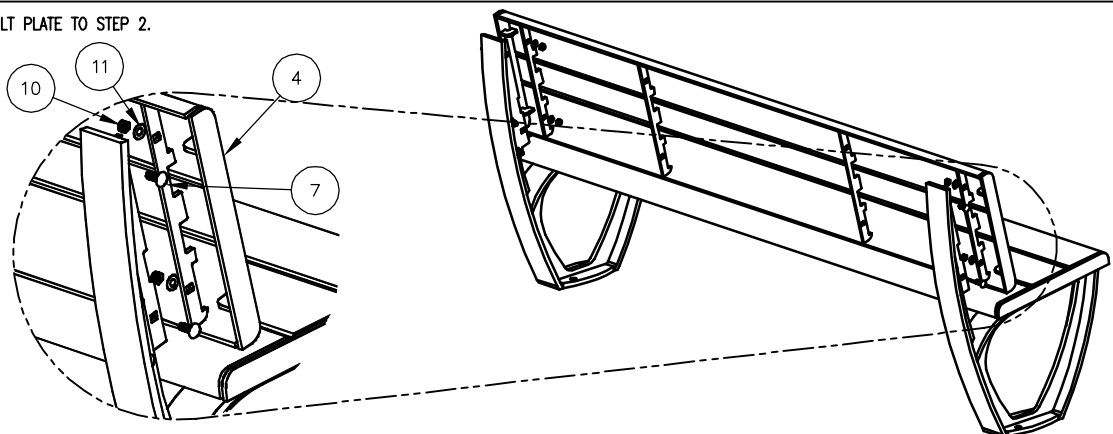

ASSEMBLY
INSTRUCTIONS

DATE DRAWN : 5/30/14
DRAWN BY : JSB
DATE REV. :
REV. BY :

REV.
A

DRAWING
NUMBER

472-60HS/S-2

SHEET
2 OF 2