

LETTERING LAYOUT  
 BOTTLES & CANS (32 GAL)  
 TRASH (32 GAL)

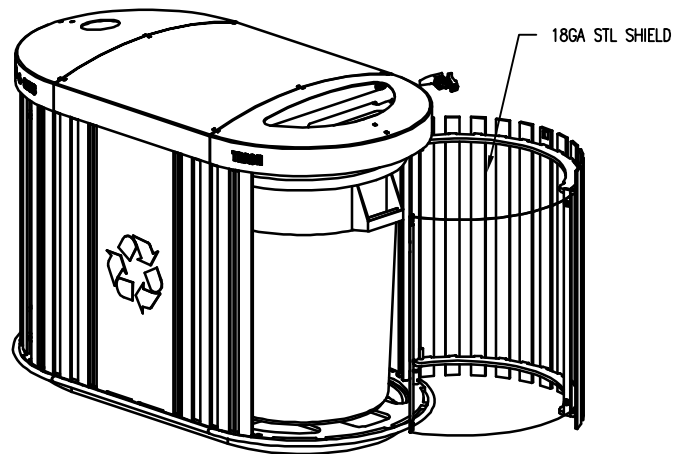
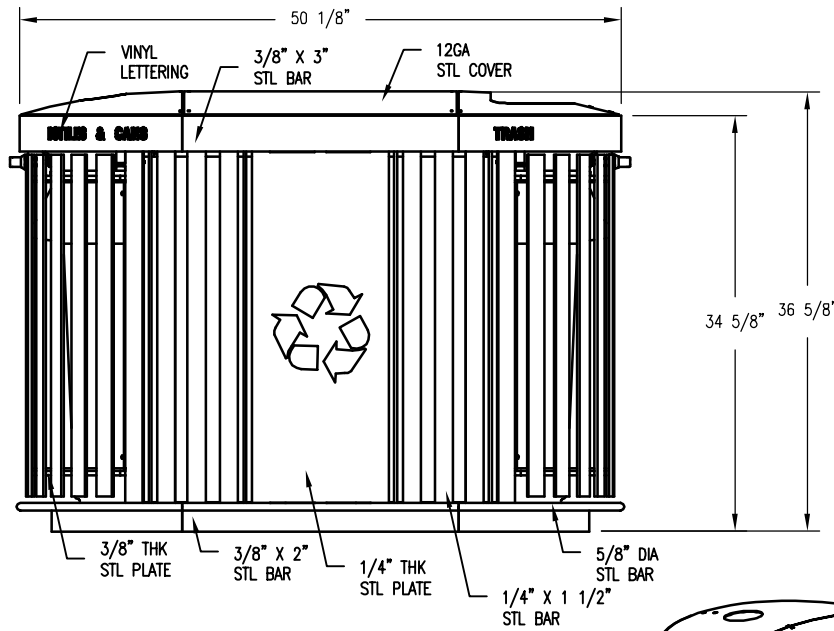

COVER NUMBERS

- 0-434-EC-10 (4" OPENING)
- 0-434-MC-14 (NO OPENING)
- 0-434-EC-13 (1/2 MOON OPENING)

NOTES

- 1.) ALL STL. MEMBERS COATED W/ ZINC RICH EPOXY THEN FINISHED W/ POLYESTER POWDER COATING.
- 2.) 1/2" X 3 3/4" EXPANSION ANCHOR BOLTS PROVIDED ( QTY 4 ).
- 3.) ENDS OF RECYCLING UNIT HINGE FOR REMOVAL OF LINERS.



RECYCLING UNIT

DATE DRAWN : 10/5/11  
 DRAWN BY : JSB  
 DATE REV. : 00/00/00  
 REV. BY : XXX

REV.  
 A

DRAWING NUMBER

434-64SH-0001

SHEET  
 1 OF 2

**NOTE:**

- 1.) RECEPTACLE SHIPPED FULLY ASSEMBLED.
- 2.) MOUNT AND ANCHOR AS SPECIFIED.

TOOLS REQ'D

- 3/4" WRENCH
- 1/2" MASONRY DRILL BIT
- DRILL

**PARTS LIST**

ITEM	QTY	PART NO	DESCRIPTION
1	1	0-434-64SH-0001	64 GAL RECYCLING RECEPT ASSEMBLY W/ SHIELD
2	2	49-32	32 GAL PL LINER W/ HANDLE, BLK

**KITS PROVIDED**

ITEM	QTY	PART NO	DESCRIPTION
3	1	K-ANCO860-4	1/2" X 3 3/4" SS ANCHOR KIT (4PC)

