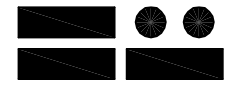

NOTES

- 1.) ALL STL. MEMBERS COATED W/ ZINC RICH EPOXY THEN FINISHED W/ POLYESTER POWDER COATING.
- 2.) 1/2" X 3 3/4" EXPANSION ANCHOR BOLTS PROVIDED.

SLAT OPTIONS

- "CEDAR" RECYCLED PLASTIC
- "GREY" RECYCLED PLASTIC
- "REDWOOD" RECYCLED PLASTIC
- "WALNUT" RECYCLED PLASTIC
- OTHER _____

 DuMor, inc. P.O. Box 142 Mifflintown, PA 17059-0142	SCALE :	NONE	TITLE :		BENCH
	DATE DRAWN :	11/16/10	REV.	DRAWING NUMBER	185-80PL
	DRAWN BY :	JSB	B		
	DATE REV. :	10/26/11			
REV. BY :	RDH			SHEET	1 OF 2

NOTE:

- 1.) DURING ASSEMBLY PROCEDURE;
DO NOT COMPLETELY TIGHTEN HARDWARE.
- 2.) THE ACTUAL PARTS WILL NOT BE NUMBERED:
NUMBERS ONLY APPLY TO DRAWING.

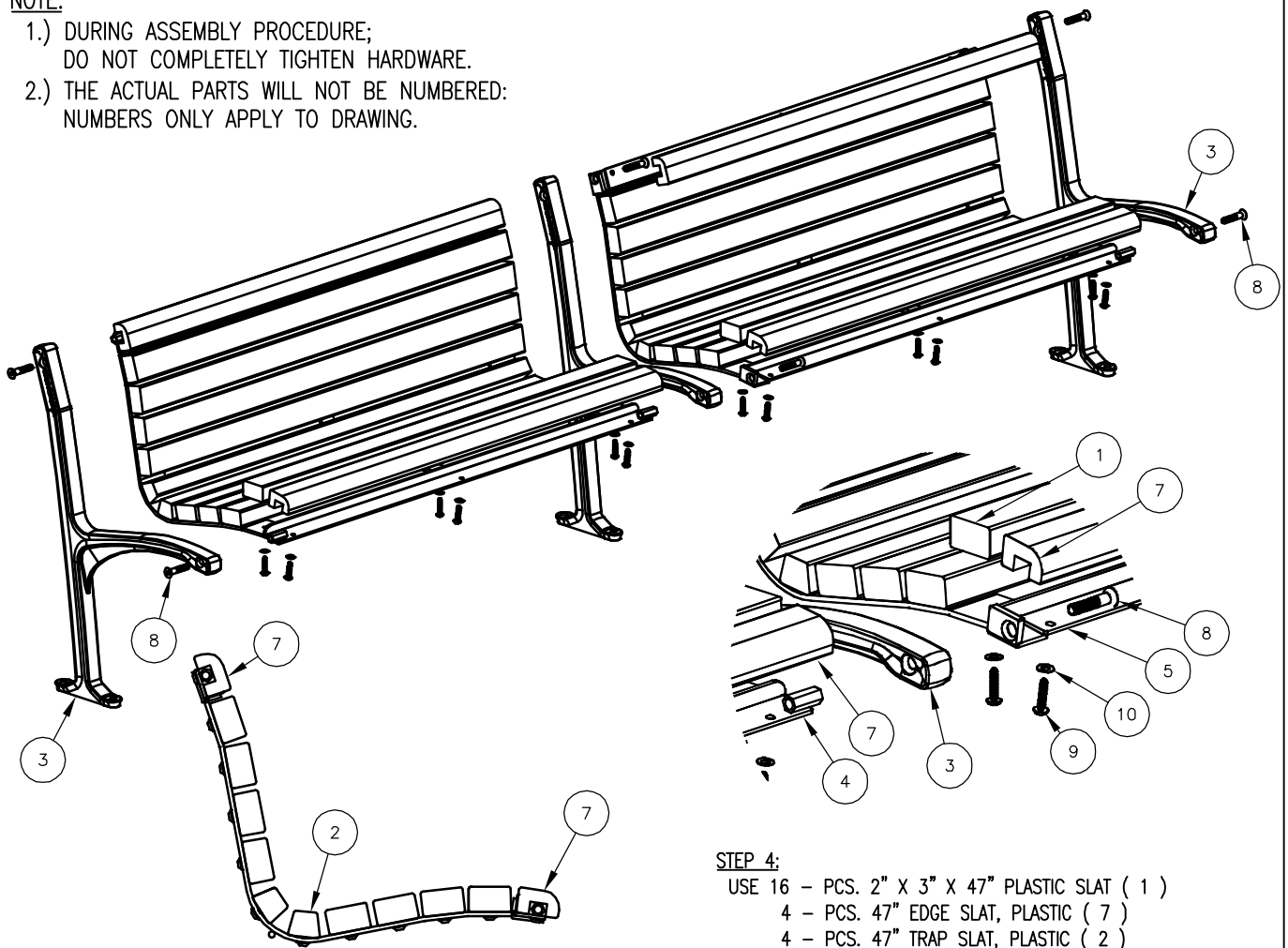

STEP 1:

- USE 1 - PC. DUCTILE IRON END SUPPORT (3)
 - 1 - PC. 4' STL SEAT FRAME (4)
 - 2 - PCS. 1/2" X 2 1/2" FLT. SKT. HD. CAP SCR. (8)
- ATTACH DUCTILE IRON END SUPPORT (3) TO 4' STL SEAT FRAME (4) USING HARDWARE (8). TIGHTEN TO SNUG FIT.

STEP 2:

- USE 1 - PC. DUCTILE IRON END SUPPORT (3)
 - 1 - PC. 4' STL LEFT SEAT FRAME (5)
 - 2 - PCS. 1/2" X 2 1/2" FLT. SKT. HD. CAP SCR. (8)
- ATTACH DUCTILE IRON END SUPPORT (3) TO 4' STL LEFT SEAT FRAME (5) USING HARDWARE (8). TIGHTEN TO SNUG FIT.

STEP 3:

- USE 1 - PC. DUCTILE IRON END SUPPORT (3)
 - 2 - PCS. 1/2" X 2 1/2" FLT. SKT. HD. CAP SCR. (8)
- ATTACH DUCTILE IRON END SUPPORT (3) TO STEP 1 & 2 ASSEMBLY USING HARDWARE (8). TIGHTEN TO SNUG FIT.

STEP 4:

- USE 16 - PCS. 2" X 3" X 47" PLASTIC SLAT (1)
 - 4 - PCS. 47" EDGE SLAT, PLASTIC (7)
 - 4 - PCS. 47" TRAP SLAT, PLASTIC (2)
 - 36 - PCS. 5/16" X 1 1/2" SS. BTN. SKT. HD. LAG (9)
 - 36 - PCS. 5/16" SS. FLAT WASHER (10)
- ATTACH PLASTIC SLATS (1, 2 & 7) TO STEP 3 ASSEMBLY USING HARDWARE (9 & 10). TIGHTEN TO SNUG FIT.

STEP 5:

UPON COMPLETION OF BENCH ASSEMBLY SQUARE ALL COMPONENTS THEN TIGHTEN ALL HARDWARE.

STEP 6:

MOUNT AND ANCHOR AS SPECIFIED.

ITEM	QTY	PART NO	DESCRIPTION
1	16	0-143-40PL-01	2" X 3" X 47" INTERIOR PLASTIC SLAT
2	4	0-165-40PL-03	47" TRAP SLAT, PLASTIC
3	3	0-185-00-01	DUCTILE IRON END SUPPORT
4	1	0-185-40-02	4' STL SEAT FRAME
5	1	0-185-40-06	4' STL LEFT SEAT FRAME
7	4	0-185-40PL-05	47" EDGE SLAT, PLASTIC
8	6	1-12-065	1/2" X 2 1/2" FLT SKT HD CAP SCR
9	72	1-13-023	5/16" X 1 1/2" SS BTN SKT HD LAG
10	72	1-22-017	5/16" SS FLAT WASHER

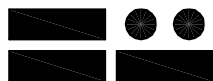

DuMor, inc.

P.O. Box 142 Mifflintown, PA 17059-0142

SCALE : NONE

DATE DRAWN : 11/16/10

DRAWN BY : JSB

DATE REV. : 10/26/11

REV. BY : RDH

TITLE :

BENCH ASSEMBLY

REV.

DRAWING NUMBER

185-80PL

B

SHEET
2 OF 2