

NOTES:

- 1.) ALL STL. MEMBERS COATED W/ ZINC RICH EPOXY THEN FINISHED W/ POLYESTER POWDER COATING.
- 2.) 1/2" X 3 3/4" EXPANSION ANCHOR BOLTS PROVIDED.

SLAT OPTIONS

- 'CEDAR' RECYCLED PLASTIC
- 'GREY' RECYCLED PLASTIC
- 'REDWOOD' RECYCLED PLASTIC
- 'WALNUT' RECYCLED PLASTIC
- OTHER _____

DuMor, inc.
 P.O. Box 142 Mifflintown, PA 17059-0142

SCALE : NONE
 DATE DRAWN : 12/11/01
 DRAWN BY : AWH
 DATE REV. : 10/26/11
 REV. BY : JSB

TITLE : BENCH
 REV. E
 DRAWING NUMBER 91-80PL

SHEET 1 OF 2

NOTE:

- 1.) DURING ASSEMBLY PROCEDURE;
DO NOT COMPLETELY TIGHTEN HARDWARE.
- 2.) THE ACTUAL PARTS WILL NOT BE NUMBERED.
NUMBERS ONLY APPLY TO DRAWING.

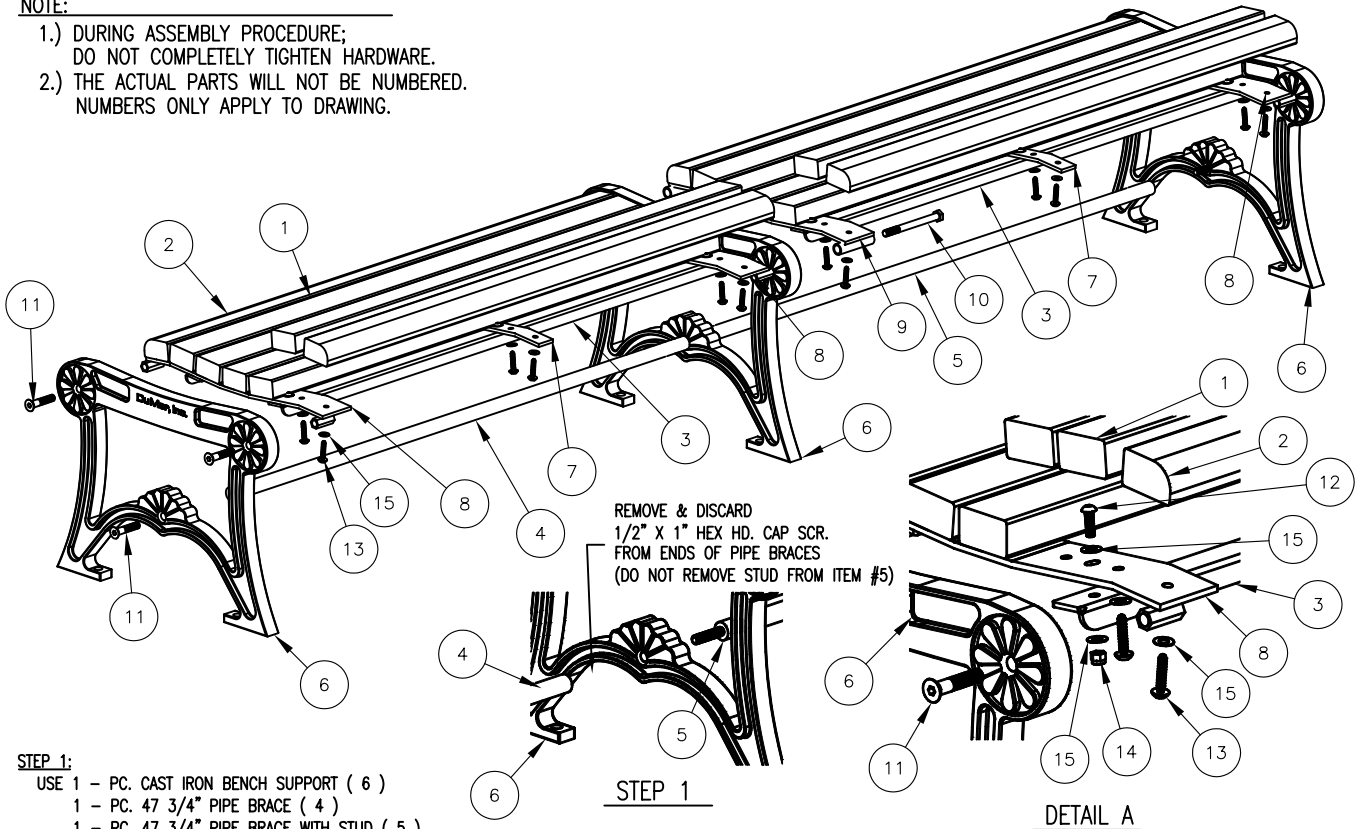

STEP 1:

- USE 1 - PC. CAST IRON BENCH SUPPORT (6)
 1 - PC. 47 3/4" PIPE BRACE (4)
 1 - PC. 47 3/4" PIPE BRACE WITH STUD (5)
 ATTACH PIPE BRACES TO CAST IRON BENCH SUPPORT (6) BY INSERTING PIPE BRACE WITH STUD (5) THROUGH CAST SUPPORT (6) THEN ATTACH PIPE BRACE (4) TO END OF STUD. TIGHTEN TO SNUG FIT.

STEP 2:

- USE 2 - PCS. CAST IRON BENCH SUPPORT (6)
 2 - PCS. 1/2" X 2 1/2" FLT. SKT. HD. CAP SCR (11)
 ATTACH CAST IRON BENCH SUPPORTS (6) TO STEP 1 ASSEMBLY USING HARDWARE (11). TIGHTEN TO SNUG FIT.

STEP 3:

- USE 2 - PCS. END CONTOUR STRAP (8)
 4 - PCS. 1/2" X 2 1/2" FLT. SKT. HD. CAP SCR. (11)
 ATTACH END CONTOUR STRAP (8) TO STEP 2 ASSEMBLY END SUPPORTS USING HARDWARE (11). TIGHTEN TO SNUG FIT.

STEP 4:

- USE 1 - PC. END CONTOUR STRAP (8)
 1 - PC. CONTOUR STRAP FOR CENTER LEG (9)
 2 - PCS. 1/2" X 5 1/2" SS. HEX HD. CAP SCR. (10)
 ATTACH END CONTOUR STRAP (8) AND CONTOUR STRAP FOR CENTER LEG (9) TO THE CENTER LEG OF STEP 3 ASSEMBLY USING HARDWARE (10). TIGHTEN TO SNUG FIT.

STEP 5:

- USE 4 - PCS. 47" SEAT BRACE (3)
 8 - PCS. 5/16" X 1" SS. BTN SKT HD CAP SCR (12)
 8 - PCS. 5/16" SS. NYLON LOCKNUT (14)
 16 - PCS. 5/16" SS. FLAT WASHER (15)
 ATTACH 47" SEAT BRACE (3) TO STEP 4 ASSEMBLY USING HARDWARE (12, 14, & 15). TIGHTEN TO SNUG FIT.

STEP 6:

- USE 2 - PCS. CENTER CONTOUR STRAP (7)
 4 - PCS. 5/16" X 1" SS. BTN SKT HD CAP SCR (12)
 4 - PCS. 5/16" SS. NYLON LOCKNUT (14)
 8 - PCS. 5/16" SS. FLAT WASHER (15)
 ATTACH CENTER CONTOUR STRAP (7) TO STEP 5 ASSEMBLY USING HARDWARE (12, 14, & 15). TIGHTEN TO SNUG FIT.

STEP 7:

- USE 10 - PCS. 2" X 3" X 47" PLASTIC INT'R SLAT (1)
 4 - PCS. 2" X 3" X 47" PLASTIC EDGE SLAT (2)
 42 - PCS. 5/16" X 1 1/2" SS. BTN. SKT. HD. LAG (13)
 42 - PCS. 5/16" SS. FLAT WASHER (15)
 ATTACH 2" X 3" X 47" PLASTIC SLATS (1 & 2) TO STEP 6 ASSEMBLY USING HARDWARE (13 & 15). TIGHTEN TO SNUG FIT. REPEAT UNTIL ALL SLATS ARE ATTACHED.

STEP 8:

UPON COMPLETION OF BENCH ASSEMBLY SQUARE ALL COMPONENTS THEN TIGHTEN ALL HARDWARE.

STEP 9:

MOUNT AND ANCHOR AS SPECIFIED.

| ITEM | QTY | PART NO | DESCRIPTION |
|------|-----|---------------|-------------------------------------|
| 1 | 10 | 0-143-40PL-01 | 2" X 3" X 47" INTERIOR PLASTIC SLAT |
| 2 | 4 | 0-143-40PL-02 | 2" X 3" X 47" PLASTIC EDGE SLAT |
| 3 | 4 | 0-16-40-06 | 47" SEAT BRACE |
| 4 | 1 | 0-57-40-04 | 47 3/4" PIPE BRACE |
| 5 | 1 | 0-57-40-05 | 47 3/4" PIPE BRACE WITH STUD |
| 6 | 3 | 0-91-00-02 | BKLESS CAST IRON BNCH SUPT |
| 7 | 2 | 0-91-00-03 | CENTER STRAP |
| 8 | 3 | 0-91-00-04 | END CONTOUR STRAP |
| 9 | 1 | 0-91-00-05 | END STRAP FOR CENTER LEG |
| 10 | 2 | 1-12-040 | 1/2" X 5 1/2" SS HEX HD CAP SCR |
| 11 | 6 | 1-12-065 | 1/2" X 2 1/2" FLT SKT HD CAP SCR |
| 12 | 12 | 1-12-116 | 5/16" X 1" SS BTN SKT HD CAP SCR |
| 13 | 42 | 1-13-023 | 5/16" X 1 1/2" SS BTN SKT HD LAG |
| 14 | 12 | 1-20-016 | 5/16" SS NYLON LOCKNUT |
| 15 | 66 | 1-22-017 | 5/16" SS FLAT WASHER |

DuMor, inc.
 P.O. Box 142 Mifflintown, PA 17059-0142

SCALE : NONE
 DATE DRAWN : 12/11/01
 DRAWN BY : AWH
 DATE REV. : 12/03/09
 REV. BY : ESS

TITLE : BENCH ASSEMBLY
 REV. D DRAWING NUMBER 91-80PL SHEET 2 OF 2