

NOTES:

- 1.) ALL STL. MEMBERS COATED W/ ZINC RICH EPOXY THEN FINISHED W/ POLYESTER POWDER COATING.
- 2.) 1/2" X 3 3/4" EXPANSION ANCHOR BOLTS PROVIDED.

SLAT OPTIONS

- "CEDAR" RECYCLED PLASTIC
- "GREY" RECYCLED PLASTIC
- "REDWOOD" RECYCLED PLASTIC
- "WALNUT" RECYCLED PLASTIC
- OTHER _____



DuMor, inc.
 P.O. Box 142 Mifflintown, PA 17059-0142

SCALE : NONE
 DATE DRAWN : 12/11/01
 DRAWN BY : AWH
 DATE REV. : 10/26/11
 REV. BY : JSB

TITLE : BENCH		DRAWING NUMBER 91-60PL	SHEET 1 OF 2
REV. E			

NOTE:

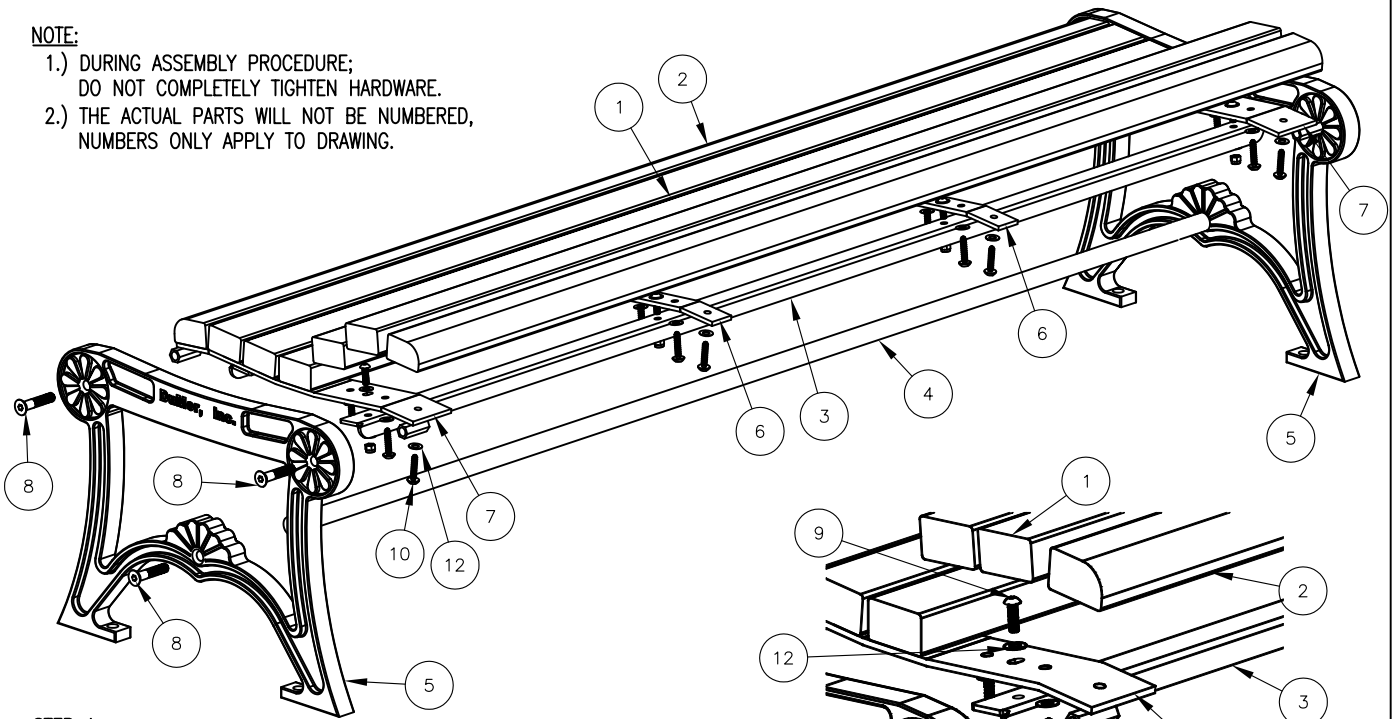
- 1.) DURING ASSEMBLY PROCEDURE;
DO NOT COMPLETELY TIGHTEN HARDWARE.
- 2.) THE ACTUAL PARTS WILL NOT BE NUMBERED,
NUMBERS ONLY APPLY TO DRAWING.



STEP 1:

- USE 2 - PCS. CAST IRON SUPPORT (5)
 - 1 - PC. 71 3/4" PIPE BRACE (4)
 - 2 - 1/2" X 2 1/2" FLT. SKT. HD. CAP SCR. (8)
- ATTACH CAST IRON SUPPORT (5) TO 71 3/4" PIPE BRACE (4) USING HARDWARE (8). TIGHTEN TO SNUG FIT.

STEP 2:

- USE 2 - PCS. END STRAP (7)
 - 4 - PCS. 1/2" X 2 1/2" FLT. SKT. HD. CAP SCR. (8)
- ATTACH END STRAP (7) TO STEP 1 ASSEMBLY USING HARDWARE (8). TIGHTEN TO SNUG FIT.

STEP 3:

- USE 2 - PCS. 71" SEAT BRACE (3)
 - 4 - PCS. 5/16" X 1" SS. BTN SKT HD CAP SCR (9)
 - 4 - PCS. 5/16" SS. NYLON LOCK NUT (11)
 - 8 - PCS. 5/16" SS. FLAT WASHER (12)
- ATTACH 71" SEAT BRACE (3) TO STEP 2 ASSEMBLY USING HARDWARE (9, 11, & 12). TIGHTEN TO SNUG FIT.

STEP 4:

- USE 2 - PCS. CENTER STRAP (6)
 - 4 - PCS. 5/16" X 1" SS. BTN SKT HD CAP SCR (9)
 - 4 - PCS. 5/16" SS. NYLON LOCK NUT (11)
 - 8 - PCS. 5/16" SS. FLAT WASHER (12)
- ATTACH CENTER STRAP (6) TO STEP 3 ASSEMBLY USING HARDWARE (9, 11, & 12). TIGHTEN TO SNUG FIT.

STEP 5:

- USE 5 - PCS. 2" X 3" X 71" INT'R PLASTIC SLAT (1)
 - 2 - PCS. 2" X 3" X 71" EDGE PLASTIC SLAT (2)
 - 28 - PCS. 5/16" X 1 1/2" SS. BTN. SKT. HD. LAG (10)
 - 28 - PCS. 5/16" SS. FLAT WASHER (12)
- ATTACH 2" X 3" X 71" PLASTIC SLATS (1 & 2) TO STEP 4 ASSEMBLY USING HARDWARE (10 & 12). TIGHTEN TO SNUG FIT. REPEAT UNTIL ALL SLATS ARE ATTACHED.

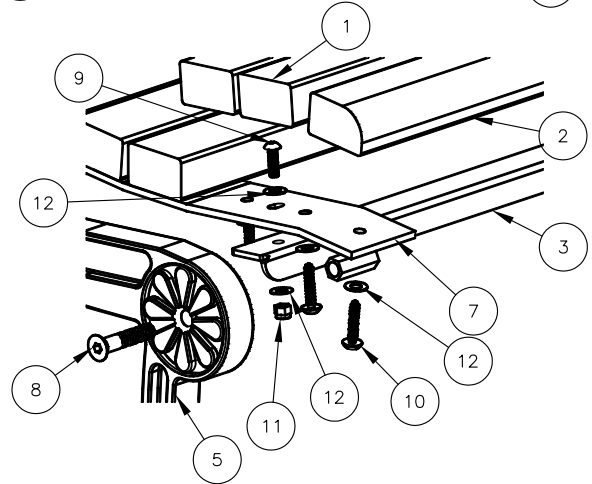

DETAIL A

STEP 6:

UPON COMPLETION OF BENCH ASSEMBLY SQUARE ALL COMPONENTS THEN TIGHTEN ALL HARDWARE.

STEP 7:

MOUNT AND ANCHOR AS SPECIFIED.

ITEM	QTY	PART NO	DESCRIPTION
1	5	0-143-60PL-01	2" X 3" X 71" PLASTIC INT'R SLAT
2	2	0-143-60PL-02	2" X 3" X 71" PLASTIC EDGE SLATS
3	2	0-16-60-06	71" SEAT BRACE
4	1	0-57-60-04	71 3/4" PIPE BRACE
5	2	0-91-00-02	BKLESS CAST IRON BNCH SUPT
6	2	0-91-00-03	CENTER STRAP
7	2	0-91-00-04	END CONTOUR STRAP
8	6	1-12-065	1/2" X 2 1/2" FLT SKT HD CAP SCR
9	8	1-12-116	5/16" X 1" SS BTN SKT HD CAP SCR
10	28	1-13-023	5/16" X 1 1/2" SS BTN SKT HD LAG
11	8	1-20-016	5/16" SS NYLON LOCKNUT
12	44	1-22-017	5/16" SS FLAT WASHER

DuMor, inc.
P.O. Box 142 Mifflintown, PA 17059-0142

SCALE : NONE
DATE DRAWN : 12/11/01
DRAWN BY : AWH
DATE REV. : 12/03/09
REV. BY : ESS

TITLE : BENCH ASSEMBLY

REV. D	DRAWING NUMBER 91-60PL	SHEET 2 OF 2
--------	------------------------	--------------