

LENGTH OPTIONS

- 6' BENCH
- 8' BENCH

NOTES

- 1.) ALL STL. MEMBERS COATED W/ ZINC RICH EPOXY THEN FINISHED W/ POLYESTER POWDER COATING.
- 2.) ALL WOOD MEMBERS TREATED W/ CLEAR PRESERVATIVE.
- 3.) 1/2" X 3 3/4" EXPANSION ANCHOR BOLTS PROVIDED.

WOOD OPTIONS

- 'C' & BTR. DOUGLAS FIR KD S4S EE
- IPE S4S EE
- OTHER \_\_\_\_\_

	BENCH	DATE DRAWN : 10/16/09	REV.	DRAWING NUMBER	185 SERIES	SHEET
		DRAWN BY : AWH	C			
		DATE REV. : 10/27/11				
		REV. BY : ESS				

PARTS LIST

ITEM	QTY	PART NO	DESCRIPTION
1	8	0-165-60-02	2" X 3" X 71" SLAT, WOOD
2	2	0-165-60-03	71" TRAP SLAT, WOOD
3	2	0-185-00-01	DUCTILE IRON END SUPPORT
4	1	0-185-60-02	6' STL SEAT FRAME
5	2	0-185-60-05	2" X 3" X 71" EDGE SLAT, WOOD
6	4	1-12-065	1/2" X 2 1/2" FLT SKT HD CAP SCR
7	48	1-13-023	5/16" X 1 1/2" SS BTN SKT HD LAG
8	48	1-22-017	5/16" SS FLAT WASHER

KITS PROVIDED

ITEM	QTY	PART NO	DESCRIPTION
9	1	K-ANCO860-4	1/2" X 3 3/4" SS ANCHOR KIT (4PC)
10	2	K-BL0524-24	5/16" LAG HARDWARE KIT (24PC)
11	1	K-FC0840-4	1/2" CAP HARDWARE KIT (4 PCS)

NOTES:

- 1.) DURING ASSEMBLY PROCEDURE;  
DO NOT COMPLETELY TIGHTEN HARDWARE.
- 2.) THE ACTUAL PARTS WILL NOT BE NUMBERED.  
NUMBERS ONLY APPLY TO DRAWING.
- 3.) UPON COMPLETION OF ASSEMBLY SQUARE  
ALL COMPONENTS THEN TIGHTEN ALL HARDWARE.
- 4.) MOUNT AND ANCHOR AS SPECIFIED.

TOOLS REQ'D

- 3/4" WRENCH
- 3/16" ALLEN WRENCH
- 5/16" ALLEN WRENCH
- 1/2" MASONRY DRILL BIT
- DRILL

1 ATTACH SLATS TO STL SEAT FRAME.

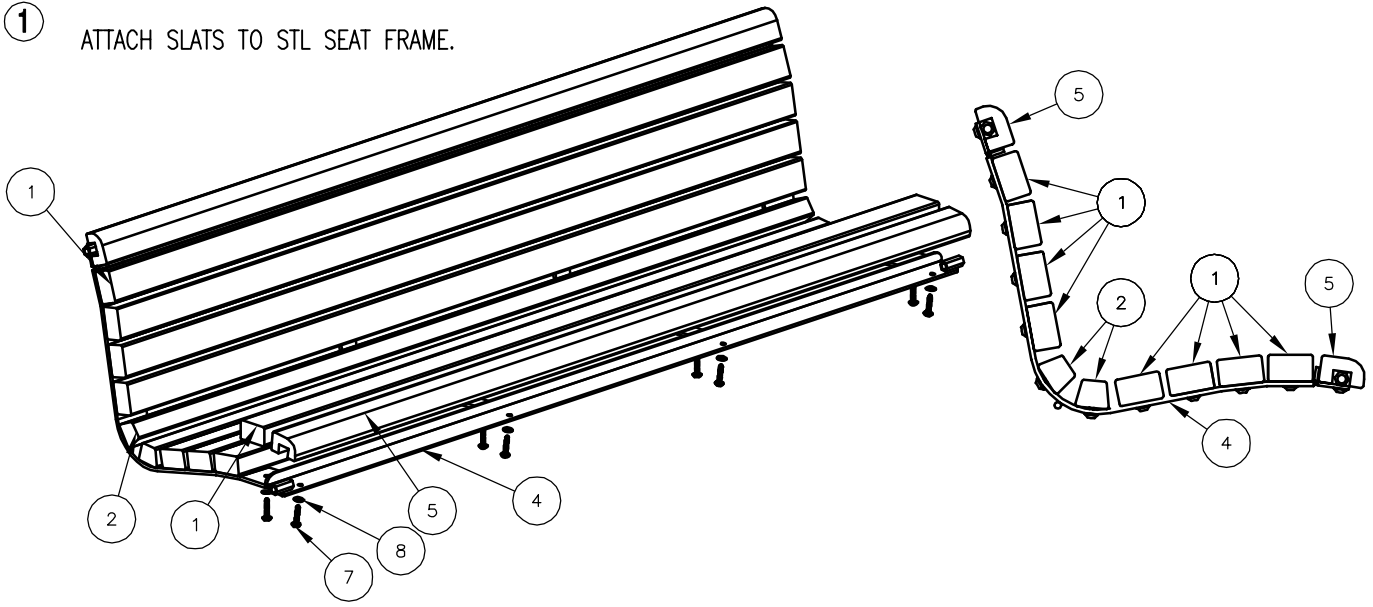

2 ATTACH END SUPPORTS TO STL SEAT FRAME.

