

WOOD OPTIONS

- 'C' & BTR. DOUGLAS FIR KD S4S EE
- IPE S4S EE
- OTHER _____

NOTES

- 1.) ALL STL. MEMBERS COATED W/ ZINC RICH EPOXY THEN FINISHED W/ POLYESTER POWDER COATING.
 - 2.) ALL WOOD MEMBERS TREATED W/ CLEAR PRESERVATIVE.
 - 3.) 1/2" X 3 3/4" EXPANSION ANCHOR BOLT FOR OPTIONS S-2 AND S-4.
 - 4.) USE 3/8" X 2" S.STL. BUTTON SOCKET HEAD LAG SCREWS FOR 3" X 4" & 4" X 4" SLATS. USE 3/8" X 1 1/2" S.STL. HEX HD LAG SCREWS FOR 2" X 4" SLATS.
- * UPCHARGE APPLIES TO SUPPORT OPTION, CONSULT YOUR LOCAL REPRESENTATIVE.

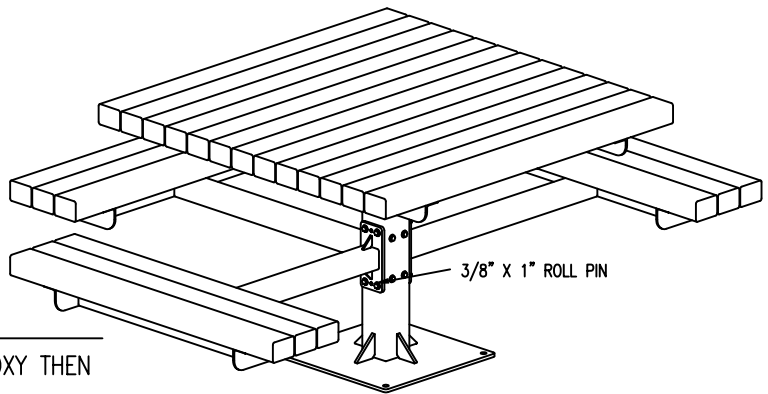

W/ 3 SEATS

- 76-23 (2" x 4")
- 76-33 (3" x 4")
- 76-43 (4" x 4")

<p>DuMor, inc. P.O. Box 142 Mifflintown, PA 17059-0142</p>	SCALE :	NONE	TITLE :		PEDESTAL TABLE
	DATE DRAWN :	1/8/00	REV.	DRAWING NUMBER	76 SERIES-3
	DRAWN BY :	JSB	J		
	DATE REV. :	12/13/11			
	REV. BY :	ESS			1 OF 2

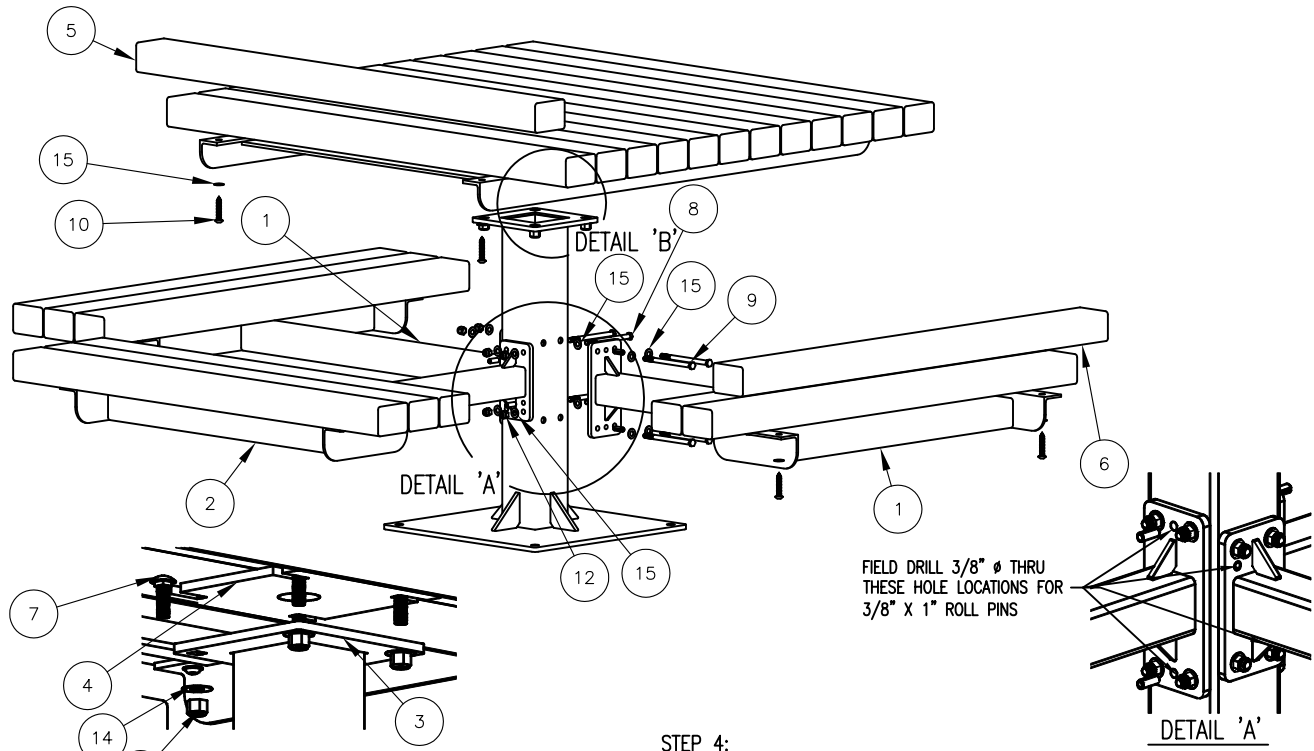

FIELD DRILL 3/8" Ø THRU THESE HOLE LOCATIONS FOR 3/8" X 1" ROLL PINS

NOTE:

- 1.) DURING ASSEMBLY PROCEDURE; DO NOT COMPLETELY TIGHTEN HARDWARE.
- 2.) THE ACTUAL PARTS WILL NOT BE NUMBERED; NUMBERS ONLY APPLY TO DRAWING.
- 3.) SEE SPEC. SHEET 1 FOR MOUNTING OPTION.

STEP 1:

USE 1 - PC. CTR. POST FOR SURFACE MOUNT, (3)
 1 - PC. TABLE TOP FRAME (4)
 4 - PCS. 1/2" X 1 1/2" SS. CGE. BOLT (7)
 4 - PCS. 1/2" SS. NYLON LOCK NUT (13)
 4 - PCS. 1/2" SS. FLAT WASHER (14)
 ATTACH TABLE TOP FRAME (4) TO CTR. POST FOR SURFACE MOUNT, (3) USING HARDWARE (7, 13, & 14). TIGHTEN TO SNUG FIT.

STEP 2:

USE 2 - PCS. SEAT SUPPORT ARM W/ 8" PLATE (1)
 4 - PCS. 3/8" X 5 1/2" SS. HEX HD. CAP SCR. (9)
 4 - PCS. 3/8" SS. NYLON LOCK NUT (12)
 8 - PCS. 3/8" SS. FLAT WASHER (15)
 ATTACH SEAT SUPPORT ARM W/ 8" PLATE (1) TO STEP 1 ASSEMBLY USING HARDWARE (9, 12, & 15). TIGHTEN TO SNUG FIT.

STEP 3:

USE 1 - PCS. SEAT SUPPORT ARM W/ 6 1/2" PLATE (2)
 4 - PCS. 3/8" X 5" SS. HEX HD. CAP SCR. (8)
 4 - PCS. 3/8" SS. NYLON LOCK NUT (12)
 8 - PCS. 3/8" SS. FLAT WASHER (15)
 ATTACH SEAT SUPPORT ARM W/ 8" PLATE (2) TO STEP 1 ASSEMBLY USING HARDWARE (8, 12, & 15). TIGHTEN TO SNUG FIT.

STEP 4:

USE 13 - PCS. 3" X 4" X 47" WOOD TABLE SLAT (5)
 9 - PCS. 3" X 4" X 43" WOOD SEAT SLAT (6)
 44 - PCS. 3/8" X 2" SS. BTN. SKT. HD. LAG SCR. (10)
 44 - PCS. 3/8" SS. FLAT WASHER (15)
 ATTACH 3" X 4" X 47" TABLE SLATS (5) AND 3" X 4" X 43" SEAT SLATS (6) TO STEP 2 ASSEMBLY USING HARDWARE (10 & 15). TIGHTEN TO SNUG FIT. REPEAT UNTIL ALL SLATS ARE ATTACHED.

STEP 5:

UPON COMPLETION OF TABLE ASSEMBLY SQUARE ALL COMPONENTS THEN TIGHTEN ALL HARDWARE.

STEP 6:

MOUNT AND ANCHOR AS SPECIFIED.

STEP 7:

USE 6 - PCS. 3/8" X 1" S.STL. ROLL PIN (11)
 BE SURE SEAT IS LEVEL. FIELD DRILL CTR POST FOR SURFACE MOUNT (3) WITH 3/8" DRILL BIT AT SEAT SUPPORT ARMS (1 & 2) OPEN HOLE LOCATIONS. SEE DETAILS 'A' AND 'B'. DRIVE IN 3/8" X 1" ROLL PIN (11).

ITEM	QTY	PART NO	DESCRIPTION
1	2	0-76-00-05	SEAT SUPPORT ARM W/8" PLATE
2	1	0-76-00-05A	SEAT SUPPORT ARM W/6 1/2" PLATE
3	1	0-76-00-06/S-2	CTR POST FOR SURFACE MOUNT
4	1	0-76-00-07	STL TABLE TOP FRAME
5	13	0-76-30-01	3" X 4" X 47" WOOD SLAT
6	9	0-76-30-02	3" X 4" X 43" WOOD SLAT
7	4	1-11-042	1/2" X 1 1/2" SS CGE BOLT
8	4	1-12-008	3/8" X 5" SS HEX HD CAP SCR
9	4	1-12-039	3/8" X 5 1/2" SS HEX HD CAP SCR
10	44	1-13-016	3/8" X 2" SS BTN SKT HD LAG SCR
11	6	1-14-003	3/8" X 1" S.STL. ROLL PIN
12	8	1-20-007	3/8" SS NYLON LOCKNUT
13	4	1-20-015	1/2" SS NYLON LOCKNUT
14	4	1-22-015	1/2" SS FLAT WASHER
15	60	1-22-024	3/8" SS FLAT WASHER

DuMor, inc.
 P.O. Box 142 Mifflintown, PA 17059-0142

SCALE : NONE
 DATE DRAWN : 1/8/00
 DRAWN BY : JSB
 DATE REV. : 12/13/11
 REV. BY : ESS

TITLE : PEDESTAL TABLE ASSEMBLY
 REV. J DRAWING NUMBER 76 SERIES-3 SHEET 2 OF 2