

WOOD OPTIONS

- 'C' & BTR. DOUGLAS FIR KD S4S EE
- IPE S4S EE
- OTHER _____

NOTES:

- 1.) ALL STL. MEMBERS COATED W/ ZINC RICH EPOXY THEN FINISHED W/ POLYESTER POWDER COATING.
- 2.) 1/2" X 1 1/2" NYLON GLIDES & 1/2" X 3 3/4" EXPANSION ANCHOR BOLTS W/ S-2 PLATES PROVIDED.
- 3.) ALL WOOD MEMBERS TREATED W/ CLEAR PRESERVATIVE.

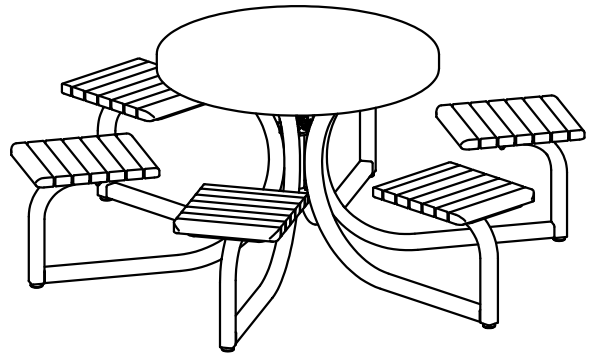

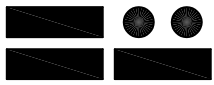
 DuMor, inc. P.O. Box 142 Mifflintown, PA 17059-0142	SCALE :	NONE	TITLE :		TABLE	
	DATE DRAWN :	10/5/12	REV.	DRAWING NUMBER	445-36	
	DRAWN BY :	JSB	A			
	DATE REV. :		REV. BY :			
					SHEET 1 OF 2	

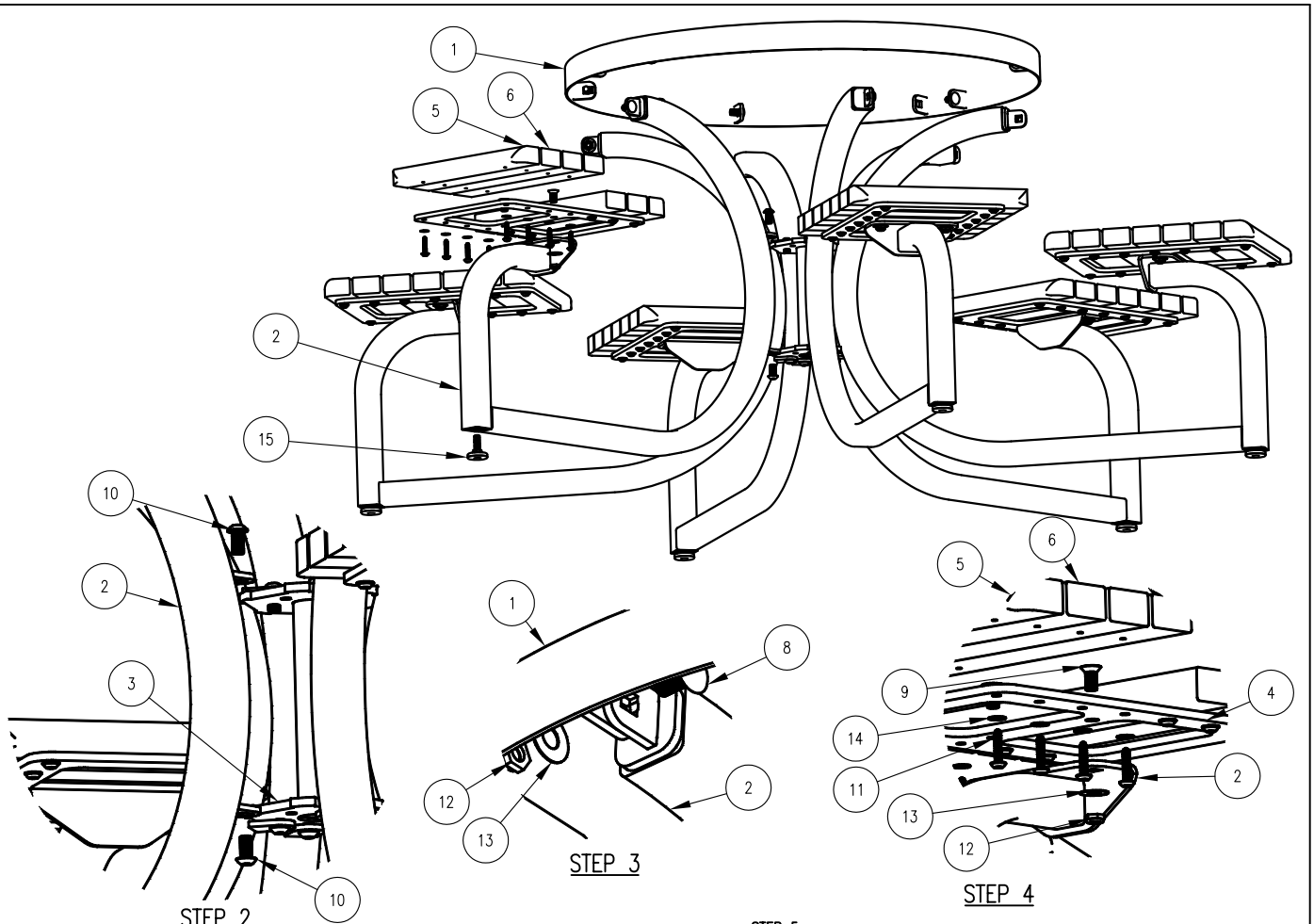

STEP 1:

USE 6 - PCS. TABLE SUPPORT LEG (2)
 6 - PCS. SURFACE MOUNT FOOT PAD (7)
 6 - PCS. 1/2" X 1 1/2" SWIVEL GLIDE (15)
 ATTACH SURFACE MOUNT FOOT PAD (7) OR 1/2" X 1 1/2" SWIVEL GLIDE (15) TO TABLE SUPPORT LEG (2) REPEAT UNTIL ALL SURFACE MOUNT FOOT PAD OR GLIDES ARE ATTACHED.

STEP 2:

USE 1 - PC. 6 SEAT BOLTING COLLAR (3)
 12 - PCS. 1/2" X 1" SS BTN SKT HD CAP SCR (10)
 ATTACH STEP 1 ASSEMBLY TO 5 SEAT BOLTING COLLAR (3) USING HARDWARE (10). TIGHTEN TO SNUG FIT. REPEAT UNTIL ALL STEP 1 ASSEMBLY ATTACHED.

STEP 3:

USE 1 - PC. STL TABLE TOP (1)
 6 - PCS. 1/2" X 1" SS CGE BOLT (8)
 6 - PCS. 1/2" SS. THIN LOCKNUT (12)
 6 - PCS. 1/2" SS. FLAT WASHER (13)
 ATTACH STL TABLE TOP (1) TO STEP 2 ASSEMBLY USING HARDWARE (8, 12 & 13). TIGHTEN TO SNUG FIT.

STEP 4:

USE 6 - PCS. SEAT BOLT PLATE (4)
 12 - PCS. 2" X 3" X 16" EDGE SLAT (5)
 30 - PCS. 2" X 3" X 16" INT'R SLAT (6)
 12 - PCS. 1/2" X 1" SS. FLT SKT HD CAP SCR (9)
 12 - PCS. 1/2" SS. THIN LOCKNUT (12)
 12 - PCS. 1/2" SS. FLAT WASHER (13)
 84 - PCS. 5/16" X 1 1/2" SS. BTN SKT HD LAG (11)
 84 - PCS. 5/16" SS. FLAT WASHER (14)
 ATTACH SEAT BOLT PLATE (4) TO STEP 3 ASSEMBLY USING HARDWARE (9, 12 & 13). TIGHTEN COMPLETELY. REPEAT UNTIL ALL SEAT BOLT PLATE ARE ATTACHED. THEN ATTACHED SLATS TO SEAT BOLT PLATE USING HARDWARE (11 & 14). TIGHTEN TO SNUG FIT. REPEAT UNTIL ALL SLATS ARE ATTACHED.

STEP 5:

UPON COMPLETION OF TABLE ASSEMBLY SQUARE ALL COMPONENTS THEN TIGHTEN ALL HARDWARE.

NOTES:

- 1.) DURING ASSEMBLY PROCEDURE;
DO NOT COMPLETELY TIGHTEN HARDWARE.
- 2.) THE ACTUAL PARTS WILL NOT BE NUMBERED;
NUMBERS ONLY APPLY TO DRAWING.

ITEM	QTY	PART NO	DESCRIPTION
1	1	0-445-00-01	STL TABLE TOP
2	6	0-445-00-02	TABLE SUPPORT LEG
3	1	0-445-06-03	6 SEAT BOLTING COLLAR
4	6	0-445-30-04	SEAT BOLT PLATE
5	12	0-445-30-05	2" X 3" X 16" EDGE SLAT, WOOD
6	30	0-445-30-06	2" X 3" X 16" INT'R SLAT, WOOD
7	6	0-94-00-02/S-2	SURFACE MOUNT FOOT PAD, PC
8	6	1-11-068	1/2" X 1" SS CGE BOLT
9	12	1-12-014	1/2" X 1" SS FLT SKT HD CAP SCR
10	12	1-12-056	1/2" X 1" SS BTN SKT HD CAP SCR
11	84	1-13-023	5/16" X 1 1/2" SS BTN SKT HD LAG
12	18	1-20-018	1/2" SS THIN NYLON LOCKNUT
13	18	1-22-015	1/2" SS FLAT WASHER
14	84	1-22-017	5/16" SS FLAT WASHER
15	6	5-48-078	1/2" X 1 1/2" SWIVEL GLIDE

DuMor, inc.
 P.O. Box 142 Mifflintown, PA 17059-0142

SCALE : NONE
 DATE DRAWN : 10/5/12
 DRAWN BY : JSB
 DATE REV. :
 REV. BY :

TITLE : TABLE ASSEMBLY
 REV. A
 DRAWING NUMBER 445-36
 SHEET 2 OF 2