

NOTES:

- 1.) ALL STL. MEMBERS COATED W/ ZINC RICH EPOXY THEN FINISHED W/ POLYESTER POWDER COATING.
- 2.) 1/2" X 1 1/2" NYLON GLIDES & 1/2" X 3 3/4" EXPANSION ANCHOR BOLTS W/ S-2 PLATES PROVIDED.

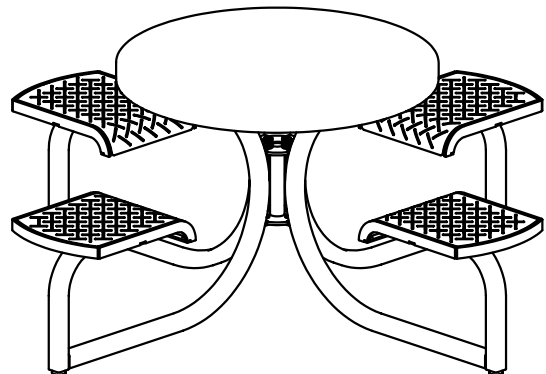

DuMor, inc.
 P.O. Box 142 Mifflintown, PA 17059-0142

SCALE : NONE
 DATE DRAWN : 10/8/12
 DRAWN BY : JSB
 DATE REV. :
 REV. BY :

TITLE : TABLE		DRAWING NUMBER 445-14	SHEET 1 OF 2
REV. A			

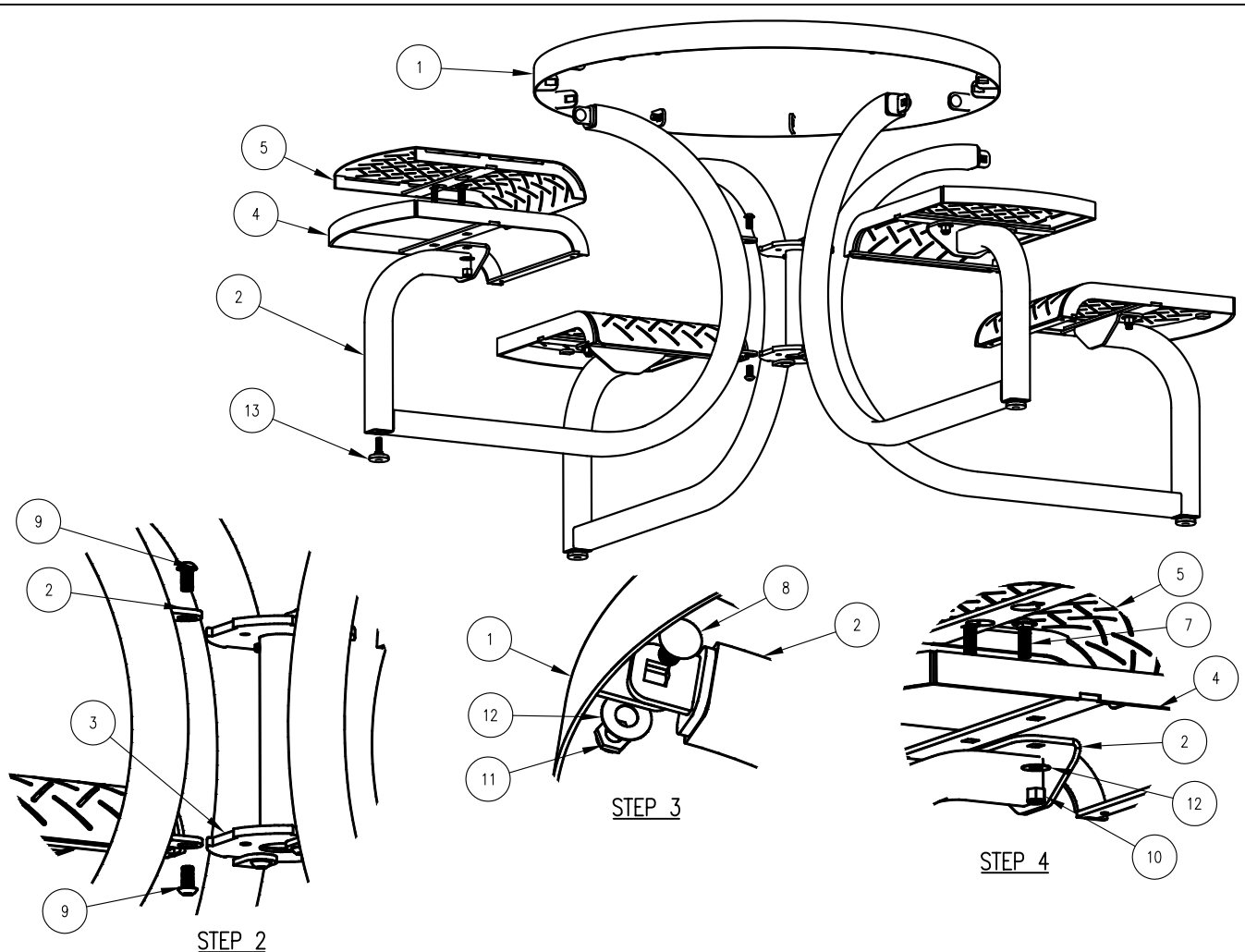

STEP 1:

USE 4 - PCS. TABLE SUPPORT LEG (2)
 4 - PCS. SURFACE MOUNT FOOT PAD (6)
 4 - PCS. 1/2" X 1 1/2" SWIVEL GLIDE (13)
 ATTACH SURFACE MOUNT FOOT PAD (6) OR 1/2" X 1 1/2" SWIVEL GLIDE (13)
 TO TABLE SUPPORT LEG (2) REPEAT UNTIL ALL SURFACE MOUNT FOOT PAD OR
 GLIDES ARE ATTACHED.

STEP 2:

USE 1 - PC. 4 SEAT BOLTING COLLAR (3)
 8 - PCS. 1/2" X 1" SS BTN SKT HD CAP SCR (9)
 ATTACH STEP 1 ASSEMBLY TO 4 SEAT BOLTING COLLAR (3) USING HARDWARE (9).
 TIGHTEN TO SNUG FIT. REPEAT UNTIL ALL STEP 1 ASSEMBLY ATTACHED.

STEP 3:

USE 1 - PC. STL TABLE TOP (1)
 4 - PCS. 1/2" X 1" SS CGE BOLT (8)
 4 - PCS. 1/2" SS. THIN LOCKNUT (11)
 4 - PCS. 1/2" SS. FLAT WASHER (12)
 ATTACH STL TABLE TOP (1) TO STEP 2 ASSEMBLY USING HARDWARE (8, 11 & 12).
 TIGHTEN TO SNUG FIT.

STEP 4:

USE 4 - PCS. STL SEAT TRIM FRAME (4)
 4 - PCS. STL INT'R SEAT (5)
 8 - PCS. 1/2" X 1 1/2" SS CGE BOLT (7)
 8 - PCS. 1/2" SS. LOCKNUT (10)
 8 - PCS. 1/2" SS. FLAT WASHER (12)
 ATTACH STL SEAT TRIM FRAME (4) & STL INT'R SEAT (5) TO STEP 3 ASSEMBLY
 USING HARDWARE (7, 10 & 12). TIGHTEN TO SNUG FIT. REPEAT UNTIL STL SEAT
 TRIM FRAME & STL INT'R SEAT ARE ATTACHED.

STEP 5:

UPON COMPLETION OF TABLE ASSEMBLY SQUARE ALL COMPONENTS THEN
 TIGHTEN ALL HARDWARE.

NOTES:

- 1.) DURING ASSEMBLY PROCEDURE;
DO NOT COMPLETELY TIGHTEN HARDWARE.
- 2.) THE ACTUAL PARTS WILL NOT BE NUMBERED;
NUMBERS ONLY APPLY TO DRAWING.

ITEM	QTY	PART NO	DESCRIPTION
1	1	0-445-00-01	STL TABLE TOP
2	4	0-445-00-02	TABLE SUPPORT LEG
3	1	0-445-04-03	4 SEAT BOLTING COLLAR
4	4	0-445-20-04	STL SEAT TRIM FRAME
5	4	0-445-20-05	STL INT'R SEAT
6	4	0-94-00-02/S-2	SURFACE MOUNT FOOT PAD, PC
7	8	1-11-042	1/2" X 1 1/2" SS CGE BOLT
8	4	1-11-068	1/2" X 1" SS CGE BOLT
9	8	1-12-056	1/2" X 1" SS BTN SKT HD CAP SCR
10	8	1-20-015	1/2" SS NYLON LOCKNUT
11	4	1-20-018	1/2" SS THIN NYLON LOCKNUT
12	12	1-22-015	1/2" SS FLAT WASHER
13	4	5-48-078	1/2" X 1 1/2" SWIVEL GLIDE

 DuMor, inc. P.O. Box 142 Mifflintown, PA 17059-0142	SCALE :	NONE	TITLE :		TABLE ASSEMBLY	
	DATE DRAWN :	10/10/12	REV.	DRAWING NUMBER	445-24	SHEET 2 OF 2
	DRAWN BY :	JSB	A			
	DATE REV. :					
	REV. BY :					