

NOTES:

- 1.) ALL STL. MEMBERS COATED W/ ZINC RICH EPOXY THEN FINISHED W/ POLYESTER POWDER COATING.
- 2.) 1/2" X 1 1/2" NYLON GLIDES & 1/2" X 3 3/4" EXPANSION ANCHOR BOLTS W/ S-2 PLATES PROVIDED.



DuMor, inc.
 P.O. Box 142 Mifflintown, PA 17059-0142

SCALE :	NONE
DATE DRAWN :	9/25/12
DRAWN BY :	JSB
DATE REV. :	
REV. BY :	

TITLE :	TABLE		
REV. A	DRAWING NUMBER	445-16	SHEET 1 OF 2

NOTES:

- 1.) DURING ASSEMBLY PROCEDURE;
DO NOT COMPLETELY TIGHTEN HARDWARE.
- 2.) THE ACTUAL PARTS WILL NOT BE NUMBERED;
NUMBERS ONLY APPLY TO DRAWING.

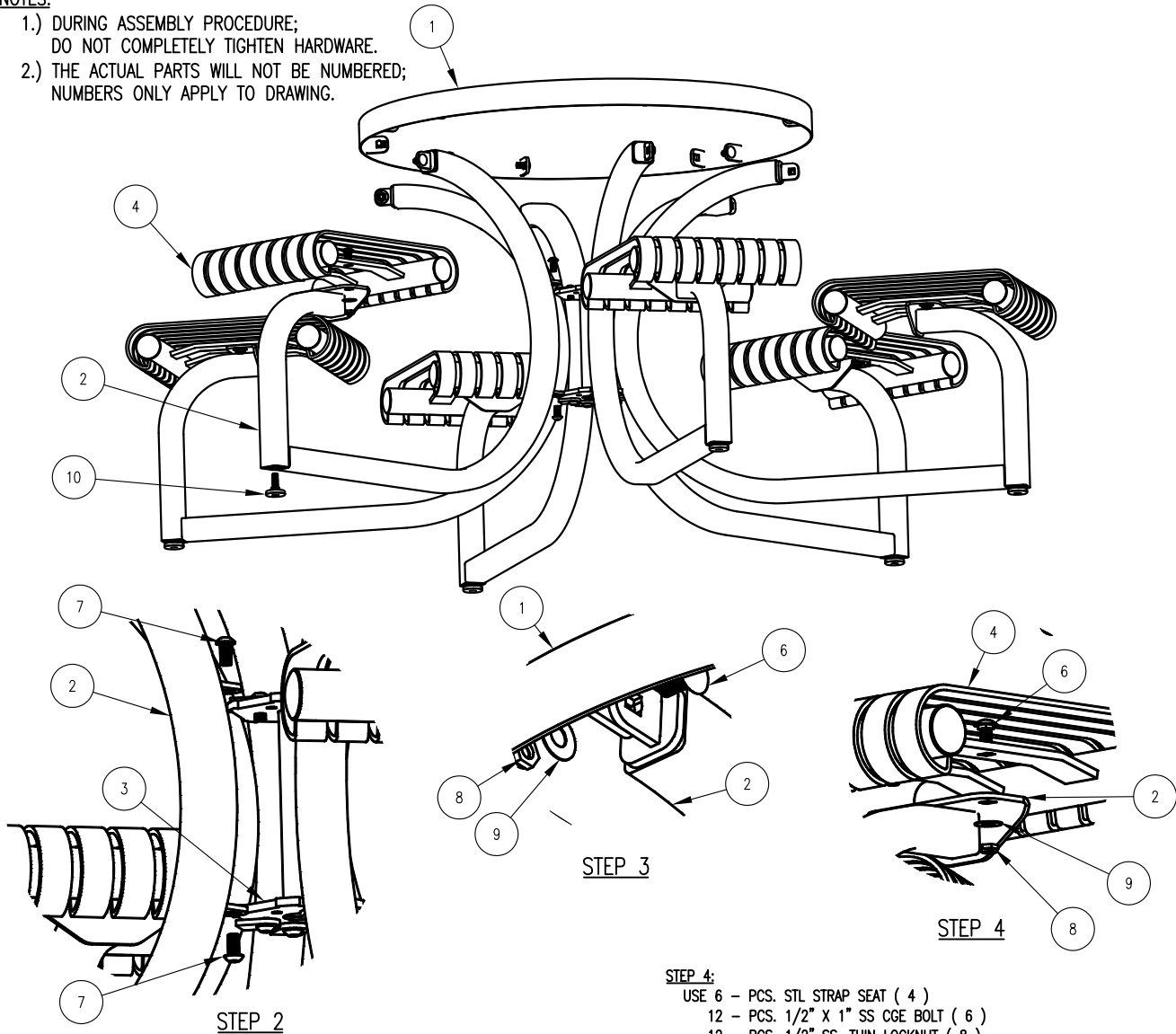

STEP 1:

- USE 6 - PCS. TABLE SUPPORT LEG (2)
 6 - PCS. SURFACE MOUNT FOOT PAD (5)
 6 - PCS. 1/2" X 1 1/2" SWIVEL GLIDE (10)
 ATTACH SURFACE MOUNT FOOT PAD (5) OR 1/2" X 1 1/2" SWIVEL GLIDE (10)
 TO TABLE SUPPORT LEG (2) REPEAT UNTIL ALL SURFACE MOUNT FOOT PAD OR
 GLIDES ARE ATTACHED.

STEP 2:

- USE 1 - PC. 6 SEAT BOLTING COLLAR (3)
 12 - PCS. 1/2" X 1" SS BTN SKT HD CAP SCR (7)
 ATTACH STEP 1 ASSEMBLY TO 6 SEAT BOLTING COLLAR (3)
 USING HARDWARE (7). TIGHTEN TO SNUG FIT. REPEAT UNTIL ALL
 STEP 1 ASSEMBLY ATTACHED.

STEP 3:

- USE 1 - PC. STL TABLE TOP (1)
 6 - PCS. 1/2" X 1" SS CGE BOLT (6)
 6 - PCS. 1/2" SS. THIN LOCKNUT (8)
 6 - PCS. 1/2" SS. FLAT WASHER (9)
 ATTACH STL TABLE TOP (1) TO STEP 2 ASSEMBLY USING
 HARDWARE (6, 8 & 9). TIGHTEN TO SNUG FIT.

STEP 4:

- USE 6 - PCS. STL STRAP SEAT (4)
 12 - PCS. 1/2" X 1" SS CGE BOLT (6)
 12 - PCS. 1/2" SS. THIN LOCKNUT (8)
 12 - PCS. 1/2" SS. FLAT WASHER (9)
 ATTACH STL STRAP SEAT (4) TO STEP 3 ASSEMBLY USING
 HARDWARE (6, 8 & 9). TIGHTEN TO SNUG FIT. REPEAT UNTIL ALL
 STL STRAP SEATS ARE ATTACHED.

STEP 5:

UPON COMPLETION OF TABLE ASSEMBLY SQUARE ALL COMPONENTS THEN
 TIGHTEN ALL HARDWARE.

ITEM	QTY	PART NO	DESCRIPTION
1	1	0-445-00-01	STL TABLE TOP
2	6	0-445-00-02	TABLE SUPPORT LEG
3	1	0-445-06-03	6 SEAT BOLTING COLLAR
4	6	0-445-10-04	STL STRAP SEAT
5	6	0-94-00-02/S-2	SURFACE MOUNT FOOT PAD, PC
6	18	1-11-068	1/2" X 1" SS CGE BOLT
7	12	1-12-056	1/2" X 1" SS BTN SKT HD CAP SCR
8	18	1-20-018	1/2" SS THIN NYLON LOCKNUT
9	18	1-22-015	1/2" SS FLAT WASHER
10	6	5-48-078	1/2" X 1 1/2" SWIVEL GLIDE

DuMor, inc.
 P.O. Box 142 Mifflintown, PA 17059-0142

SCALE : NONE
 DATE DRAWN : 9/25/12
 DRAWN BY : JSB
 DATE REV. :
 REV. BY :

TITLE : TABLE ASSEMBLY
 REV. A
 DRAWING NUMBER 445-16
 SHEET 2 OF 2